



User's Product Manual

850RBs

LifeCore LC-850RBs Recumbent Bike

Introduction

Congratulations on your purchase of the 850RBs Recumbent Bike. This product has been designed and manufactured to meet the needs and requirements of domestic use.

By Choosing your 850RBs Recumbent Bike, you have made a wise decision that will improve the health of you and your family. Being fit and healthy will improve your energy level and your quality of life.

Cardiovascular training is vital for all ages and the 850RBs Recumbent Bike provides a more effective workout, producing better results, and will encourage you to reach your fitness goals and maintain the body you have always wanted.

In order to make your experience with LifeCore the best it can be, please review the enclosed user's manual prior to assembly and first use. Be sure to keep the instructions for reference and/or maintenance.

We also offer a complete line of fitness equipment; please take a moment to review our other excellent products at www.lifecorefitness.com. Should you have any questions, please contact us. Your feedback and ideas about your experience with LifeCore are also very important to us. Write to us at:

LifeCore Fitness Inc.
2575 Pioneer Ave. Suite 101
Vista, CA 92081

We wish you lots of success and fun while training!

Purchaser's Reference Information

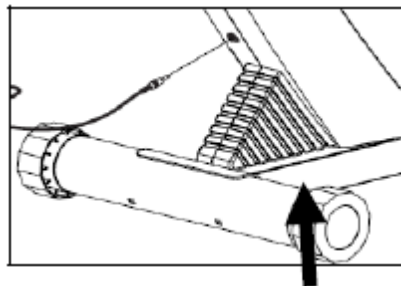

Serial Number is located on the frame

Please send in the attached warranty card and a copy of the original receipt or register online at www.lifecorefitness.com within (10) days of purchase to register your product with LifeCore Fitness.

Table of Contents

Introduction.....	1
Purchaser's Reference Information	1
Table of Contents.....	2
Safety instructions and Warnings.....	3
Assembly Instructions	4
How to Adjust the Seat Pad & Back Pad Position.....	10
How to Transport the Bike	10
Console Operation Instructions	11
Monitoring Your Heart Rate	18
Heart Rate Monitoring Devices	19
Care and Maintenance	20
Warranty Card.....	21



“We Fit Your Life”

Safety Instructions & Warnings

The 850RBs Recumbent Bike is designed and manufactured to meet or exceed all domestic and international safety standards. However, certain precautions need to be followed when operating any exercise equipment.

General safety instructions:

1. It is important to consult your physician before any exercise program.
2. Pregnant women should consult with their physician before beginning any exercise program. He/she can help determine the exercise program that is the most appropriate for your age and physical condition.
3. If you experience dizziness, nausea, chest pains or other abnormal symptoms during exercise, stop the exercise session immediately. Consult your physician before continuing your exercise.
4. Keep children away from the equipment. Hands and feet may get caught in the pedals or other moving parts, which could result in serious injury.
5. No more than one person should ever use the product at a time.
6. Pets should never be allowed near unit.
7. Always wear proper clothing and shoes when exercising. Drink plenty of fluids when exercising.
8. Always stretch and warm up before starting any exercise program.
9. Never operate this unit if it is damaged or broken. Contact your authorized dealer for service.
10. Place your equipment on a solid, level surface when in use.
11. Place your unit in an area with enough clearance to operate the equipment.
12. Make sure all components are fastened securely at all times.

Product safety instructions:

1. Start your exercise program gradually. Exercise only for a few minutes the first day to let your body adjust to the new exercise.
2. Slowly increase your exercise time and intensity over the first two weeks. If you increase your intensity too rapidly, or fail to warm up properly, you can increase the risk of injury.
3. Use of this machine with worn or weakened parts, may result in injury to the user. We strongly suggest replacing it immediately. Use only the accessory attachments recommended by the manufacturer.
4. Unit maximum weight limit is 300LBS
5. It is recommended the unit be plugged into a surge protector. Do not place machine in an area of high voltage or electromagnetic fields.
6. Whenever mounting or dismounting from the exercise machine, make sure that the unit is not in motion and use caution to prevent injury. Use the handlebars or a helper whenever additional stability is required.
7. Make sure that all components are fastened securely including but not limited to seat, pedals, handlebars, or any electric components.
8. Never place any open containers of any type directly on the unit, only containers with lids are recommended to be used with the appropriate water bottle holder.
9. Keep machine clear of any obstructions, heavy machinery, and never place objects on or against machine. Perform proper maintenance as recommended in this manual.
10. Failure to follow these instructions will void the units warranty and the manufacturer or distributor assumes no responsibility for personal injury or property damages related to the product if unit is ever used incorrectly or for reasons other than exercise.
11. Save this manual for future reference.

Assembly Instructions

The LifeCore 850RBs Recumbent Bike is made from the best materials and has been tested and received a quality control review prior to its packaging to ensure the correct parts and proper fitting of each component.

Before assembly of your product, distinguish a proper and appropriate location for the unit where there is easy access to an electrical outlet with a surge protector. Unpack the box in a clear work area to allow smooth assembly. Remove all of the parts from the packing material; however, do not discard packing material until assembly is complete. Double check packing materials to ensure no missing parts were left behind.

Note that some hardware may be preassembled to components in order to help with assembly; tools have also been provided to assist with assembly. If you are missing any parts, assembly bags or need assistance with assembly please call LifeCore Fitness at 1-888-815-5559.

Below are step by step assembly instructions:

Tools Required:

13 mm wrench
15 mm wrench
Philips Screw driver
6mm Allen wrench
5mm Allen wrench
4mm Allen wrench

Step 1: Rear Stabilizer Assembly

Tool Needed:

13mm wrench

(See Figure 1) Attach the rear stabilizer (B1) to the main frame with bolts (J1), arc washers (J2) and nuts (J3).

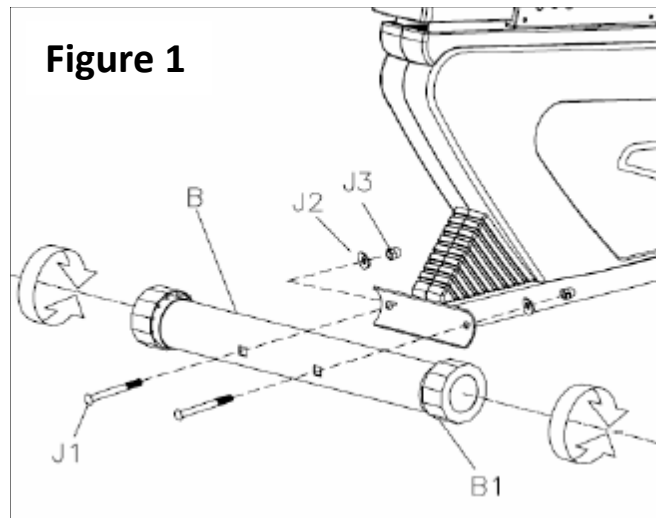

Step 2: Front Stabilizer Assembly

Tool Needed:

13mm wrench

(See **Figure 2**) Attach the front stabilizer (C) to the main frame with bolts (J1), arc washers (J2) and nuts (J3).

Note: Once the stabilizers are assembled, check to see if the machine is stable. If the machine is unstable, adjust the (B1) rear end caps to level the machine.

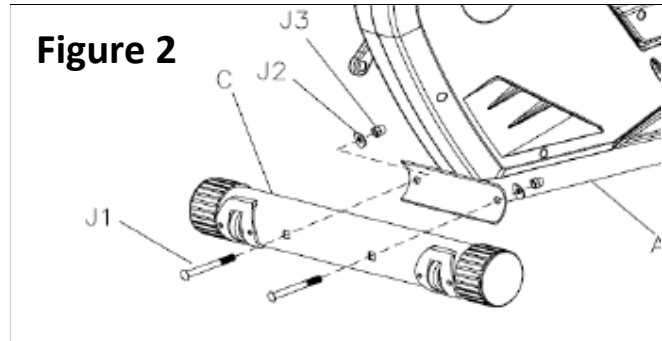

Step 3: Central Support Tube Assembly

Tool Needed:

5mm Allen wrench

- 1) Slide the decorative cover (E2) onto the bottom of the central support tube (E1).
- 2) (See **Figure 3**) Connect heart rate wire (E4) to lower heart rate wire (A2) and connect computer wire (E3) to the servo motor cable (A3).
- 3) Place the central support tube (E1) on the main frame and use bolts (J4) to tighten the central support tube.

Note: Ensure that all wires are properly connected and stored inside the central support tube. Be careful not to pinch the wires.

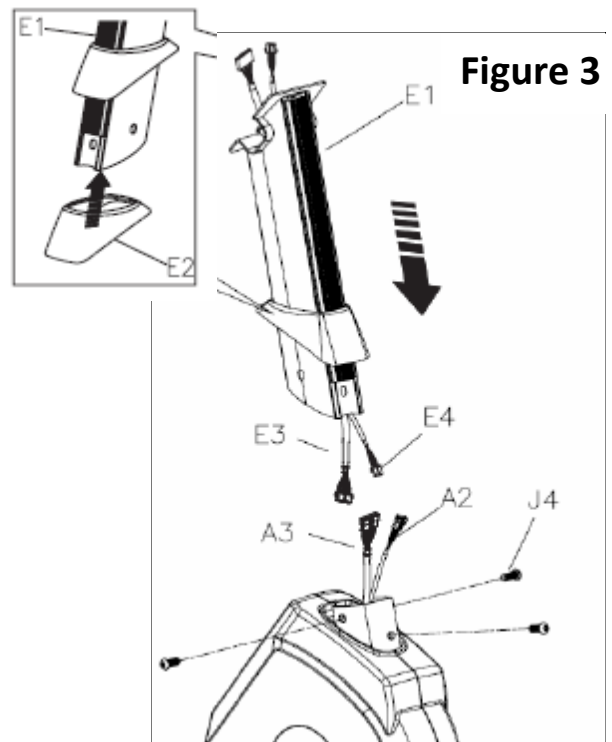

Step 4: Small Handle Bar & Water Bottle Holder Assembly

Tool Needed:
5mm Allen wrench

- 1) (**See Figure 4**) Place small handle bar (D) onto the metal plate of the central support tube (E1) and tighten the handle bar with bolts (J6) and washers (J7).
- 2) Position the water bottle holder (L1) in the middle of the central support tube (E1) and tighten it with 2 screws (J8).

Figure 4

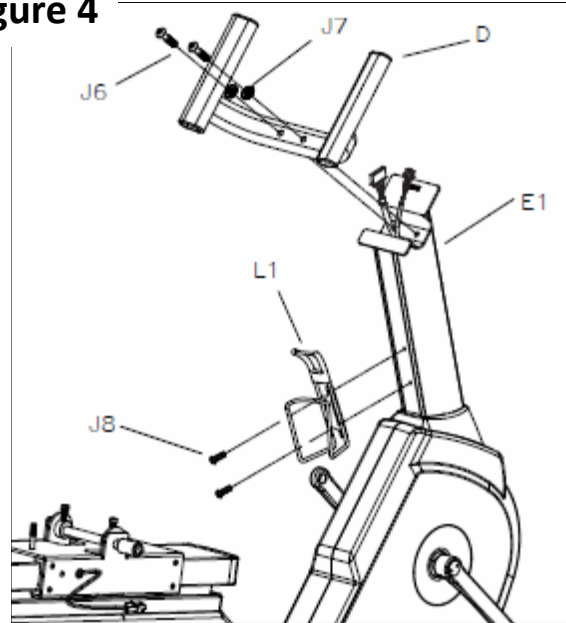

Step 5: Console Assembly

Tool Needed:
Philips screw driver

- 1) Remove screws (G1) from the back of console housing.
- 2) Connect computer wire (E3) and heart rate wire (E4) to console (G).
- 3) (**See Figure 5**) Slide console (G) onto the central support tube (E1). Secure and tighten the console onto the central support tube with screws (G1).

Note: To prevent wire being pinched, please make sure the wires are pushed back and stored inside the central support tube before sliding and tightening the console.

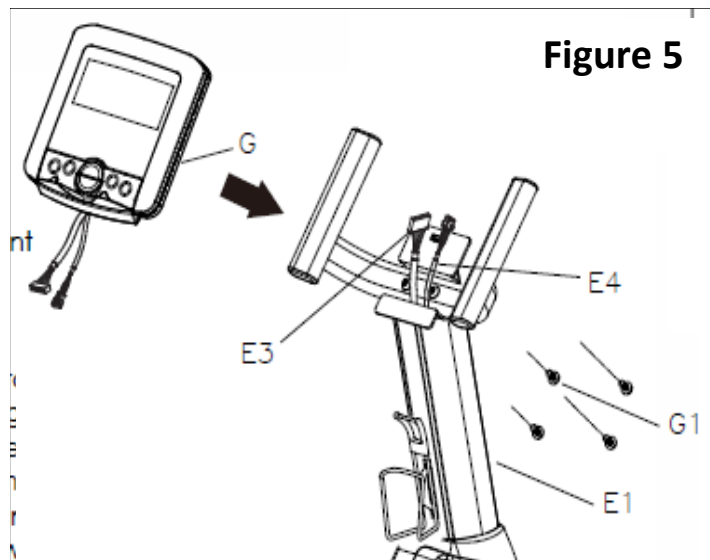

Step 6: Seat Pad & Back Pad Assembly

Tool Needed:

6mm Allen wrench

- 1) (**See Figure 6**) Fit seat back pad to seat pad tube (K) with knobs (J11) and washers (J7).
- 2) Assemble seat pad (H1) onto seat pad tube using bolts (J10).

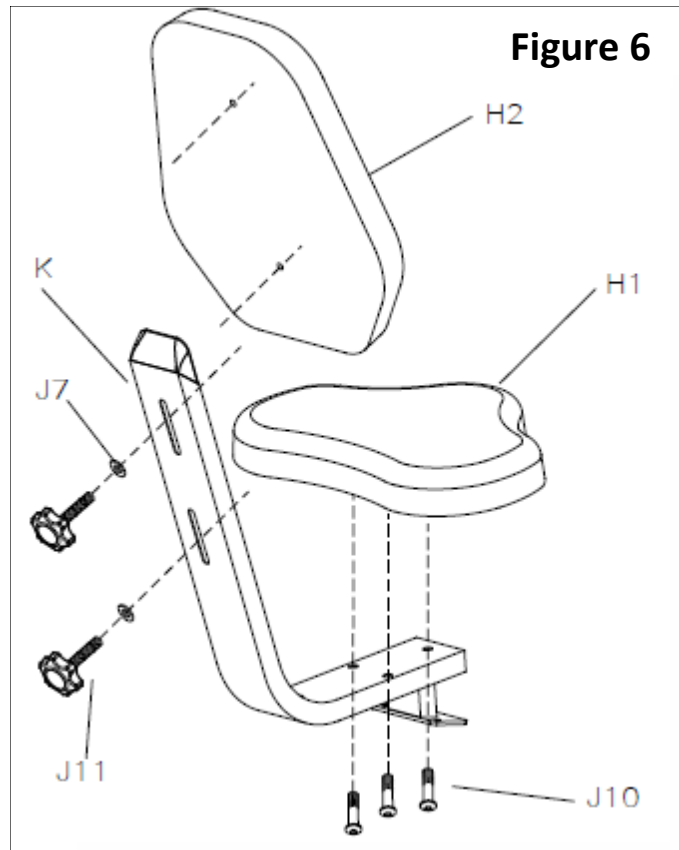

Step 7: Seat Structure & Left Handle Bar Assembly

Tool Needed:

5mm Allen wrench

13mm wrench

- 1) (**See Figure 7**) Connect seat structure (K) to seat frame (A35) using bolts (J5), washers (J7) and nuts (J3).
- 2) Connect hand pulse wire (A5) to hand pulse sensor wire (F1-1) which is coming out of left side handle bar (F1).
- 3) Secure the left handle bar by tightening the bolts (J5). Make sure not to pinch the wires while tightening the hardware.

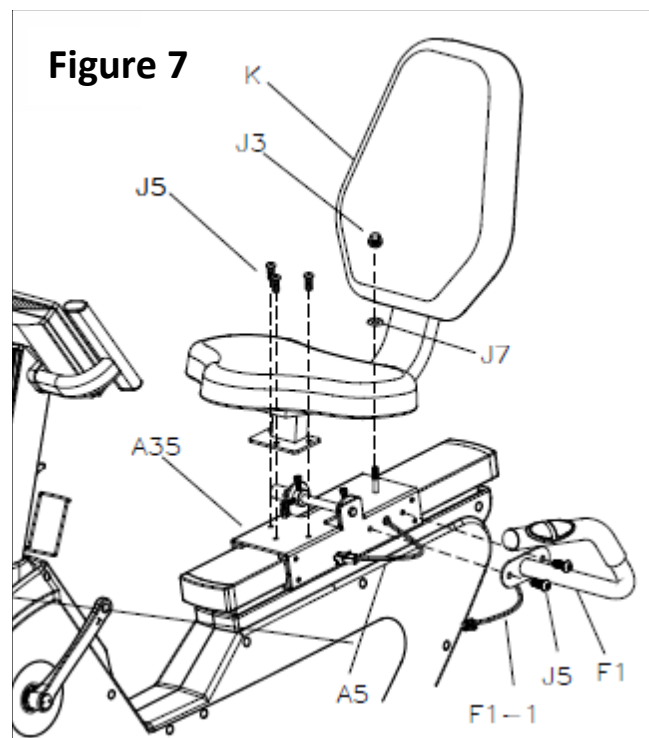

Step 8: Stop Bar & Right Handle Bar Assembly

Tool Needed:

5mm Allen wrench

- 1) (See Figure 8) Insert the stop bar (P) into the receiver and tighten it with bolt (J9).
- 2) Connect hand pulse wire (A6) to hand pulse sensor wire (F2-1) which is coming out of right side handle bar (F2).
- 3) Secure the right handle bar onto seat frame by tightening the bolts (J5). Make sure not to pinch the wires while tightening the hardware.

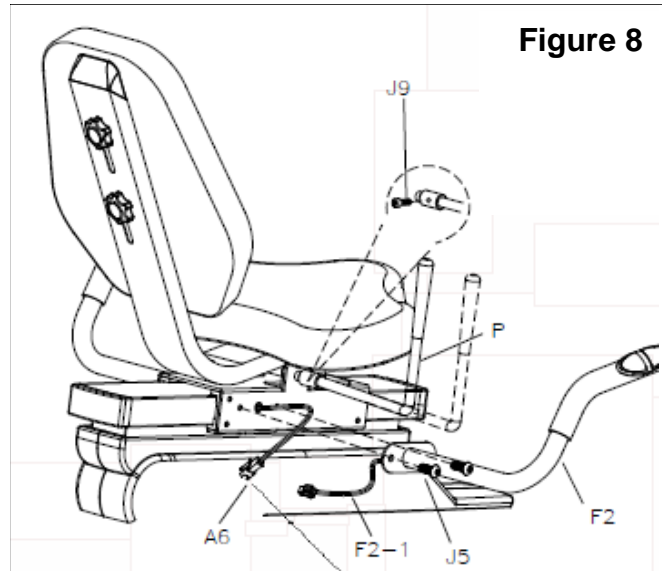

Step 9: Pedal Assembly

- 1) Locate the right pedal. There is Left and Right marker on the pedal itself for identification.
- 2) Attach the right pedal (M2) into crank arm by threading it in a clockwise direction.
- 3) Attach the left pedal (M1) into crank arm by threading it in a counter-clockwise direction.
- 4) Use wrench and apply additional torque to make sure the pedals are extremely tight. (Torque wrench is preferred.)
- 5) Afterwards, insert the pedal straps into the pedals and push down the "PRESS" button to lock in place.

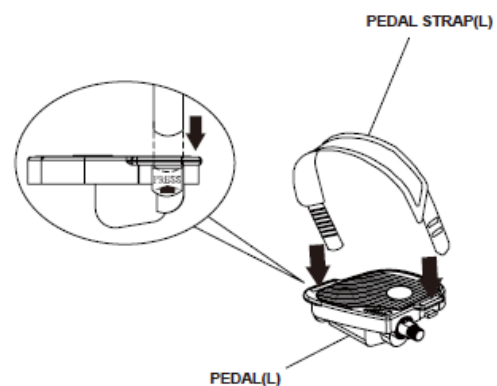
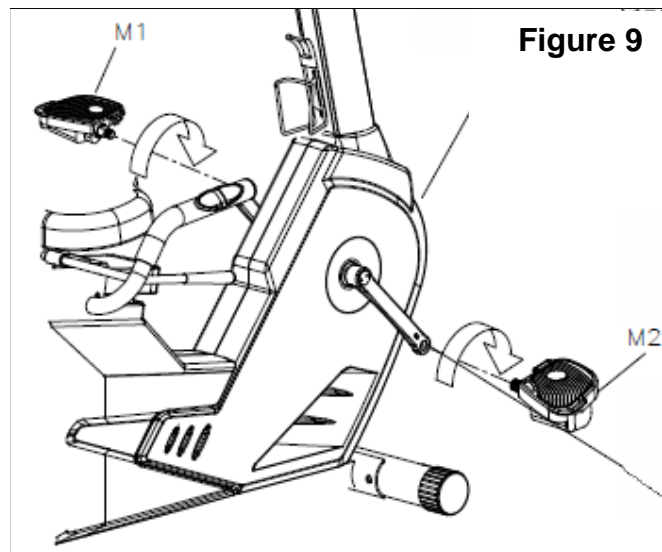

Step 10: AC Adaptor Option

This product is powered by a generator. AC adapter is included for additional power needed in the case of RPM being too low. The AC Adaptor is located at the rear of the machine; flip the switch on the AC Adaptor to the **ON** position. "0" sign is for **OFF**; "I" sign is for **ON**. Flip the switch on the adaptor to turn off your machine after use. **ONLY** use the adaptor that comes with the machine.

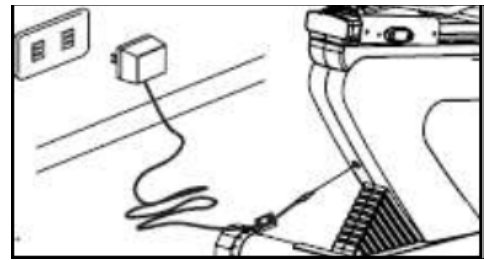

Congratulations!

You have completed assembly of your 850RBs Recumbent Bike

How to Adjust the Seat Pad & Back Pad Position

Seat Pad adjustment: pull up on the stop bar (P) and set the seat to the most comfortable location which allows the rider to have a smooth and comfortable motion. The proper way to cycle is to have the knees slightly bent during the furthest pedal rotation.

Back Pad adjustment: loosen knobs (J11) and adjust the back pad to the most comfortable position. Then tighten the knobs back to secure the pad.

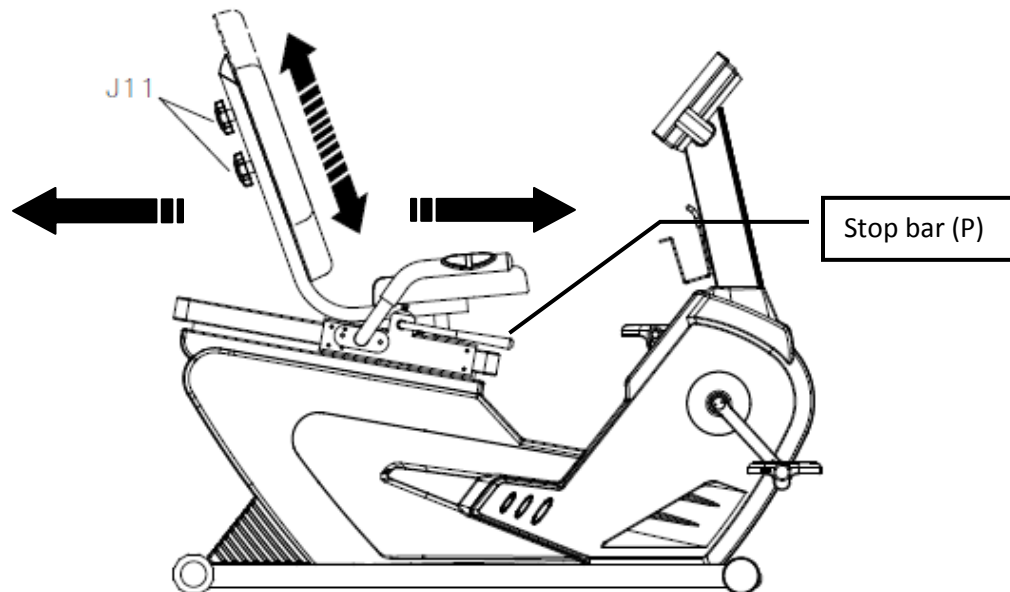

How to Transport the Bike

If the machine needs to be transported to a different location, stand at the front of the machine and push down on the front handle bars until the weight of the machine is transferred to the transport wheels and the rear of the machine is in the air. You can now easily move the machine to a new location. Gently set the machine down at its new location.

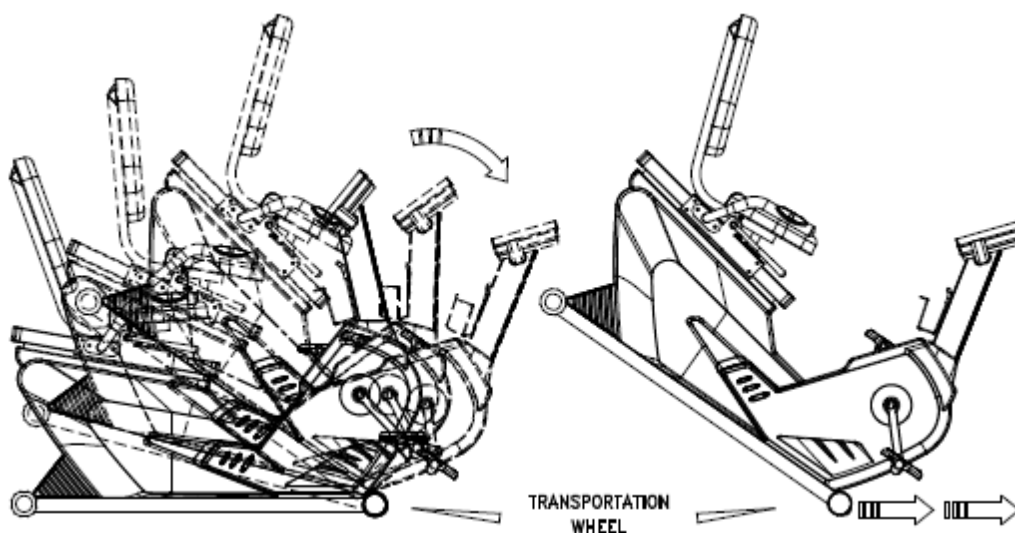

Console Operation Instructions

Please read the console operation instruction thoroughly and get familiar with the console layout. Practice using this console before you start in order to get a better understanding of the functions. Below is the console layout and detailed operation instructions.

This product is powered by a generator; please make sure you pedal above 35rpm to provide sufficient power to the console. In the case of insufficient power, the AC adapter will supply the additional power needed to ensure console operation.

1. CONSOLE LAYOUT



2. DISPLAYS

a. **Dot matrix profile window:**

Displays program profile during program setting and executing. The program profile will be different according to which program is selected.

There are 16 columns of LCD representing 16 segments of time; each segment time = total program time divided by 16 columns. During exercising, a column of LCD will blink to indicate the time segment you are currently in and show your workout progress.

There are also 16 rows of LCD representing 16 levels of resistance. Each row represents 1 level of resistance. There is also level display on the right side of dot matrix profile window to display the resistance level. The appropriated row of LCD will light up when you adjust the resistance level.

b. **Data display windows:** There are 5 data display windows displaying time, rpm/speed, distance, watt/calories and pulse. During program setting, the appropriated data window will blink to indicate which data you are setting currently. Press ▲/▼key to adjust the value and ENTER key to confirm the value.

Note:

- i. *During data displaying, speed/RPM window will display speed & RPM each for 5 seconds; switch back & forth. Same as watt/calories display.*
- ii. *The default value setting will be updated to the last setting if it has been changed. Pressing & holding the RESET key for a couple of seconds will reset them back to factory defaults.*
- iii. *Setting a number besides 0 in those slots will count the number down. If it's set at 0, it will count up.*

c. **User profile setting window:** During user profile setting, each indicator graphic will light up to show which setting is selected and dot matrix window will display its value. Press ENTER key to confirm selection/value or ▲/▼ key to change the selection/value.



for gender selection; AGE for age entry; H.t for height entry and W.t for weight entry.

d. **Program category selecting window:** During program category selection, all program categories will light up and flash. Press ▲/▼key to change the selection and ENTER key to confirm the category selection. There are 5 program categories: manual, program, watt, personal and H.R.C.

e. **H.R.C. program window:** During H.R.C. program selection, each indicator graphic will light up to show which H.R.C. program is selected. Press ENTER key to confirm the program selection or ▲/▼key to change the selection. There are 4 H.R.C. programs: TAG (target), 90%, 75% & 55%.

There is also a heart symbol (♥) inside this window which blinks every time it picks up a heart rate signal from the heart rate device.

Note: Display sleep mode: If there is no sufficient power to the console, the display will shut down and enter “sleep” mode. Previous activities will be stored for 2 minutes. To resume, simply pedal again. If no power for more than 2 minutes, the console will be reset and previous activities will be lost, except for the saved User information.

3. **KEYS:** There are 6 function keys for program operation.

a. **START/STOP key:** Pressing the START/STOP key once will execute the programs and all data will start counting. Pressing the START/STOP key one more time will enter program pause mode and all data will stop counting. To exit pause mode, simply press START/STOP one more time to resume program.

b. **RESET key:** Pressing the RESET key once will reset and return back to program selecting mode. If you are in the middle of a program, you will have to pause the program first before you can reset the console. All previous entered value such as Time; Distance; Calories and Pulse will be saved as the updated default value.

Pressing and holding the RESET key for a couple of seconds will reset the console back to the beginning of the setting sequence: user profile selecting. All previous entered value such Time; Distance; Calories and Pulse will be reset to 0.

c. **ENTER key:** Press ENTER key to confirm the program setting, selection or data entry.

d. **▲/▼key:** Press ▲/▼key to go to the next user profile setting; next program selection; adjusting data entry during program setting or level adjusting during program execution.

e. **RECOVERY key:** This is a function designed to see how much time it takes for the heart to recover after a workout and therefore recommends a fitness level. The program will take 60 seconds to figure out your fitness level and present a fitness score.

Press RECOVERY key after a workout, the time display will start counting down from 60 seconds and pulse display will display your current heart rate. Do not press any key or pedal during the 60 second period. After 60 seconds, the dot matrix display will show your fitness score: F1 – F6. Below is a chart for the fitness level vs. score.

Score	Fitness Level	Heart rate
F1	Excellent	50+
F2	Good	40 - 49
F3	Fit	30 - 39
F4	Average	20 – 29
F5	Below Average	10 - 19
F6	Challenge	10-

Note: In order for this function to work, the pulse reading has to be active thru out the testing period.



4. PROGRAMS

Make sure the console is powered before you start using this console. Turn the On/Off switch located on the back of the bike to the ON position. The dot matrix profile display will show: ML; that means it is in English (vs. Metric) setting.

a. **User profile:** Before picking a program to start; it's recommended to set up your user profile first. It will ensure workout data calculation is more accurate and future workouts are more convenient. There are 4 user spaces for saving user profiles: U1 – U4; user information will be saved permanently unless user changes it. U0 is for a guest user which means no user profile will be saved into U0; it will return to default value after reset.

Below are the step by step instructions for setting up the user profile:

Step 1: Select User Number: Power up the console or press & hold RESET key for a couple of seconds, the console will enter user profile selection mode. In user profile selection mode (dot matrix window shows U1, etc.), press ▲/▼key to pick a desired user number (U1-U4) and press ENTER to confirm. After user number confirmation, the appropriated user no. will display on the user profile setting window for profile setting.

Step 2: Select User Gender: Male or female symbol   will light up; press ▲/▼key to change selection and ENTER key to confirm selection.

Step 3: Set up User Age: Default 25 years old or last entered age will appear on the dot matrix window. Press ▲/▼key to adjust the age and ENTER key to confirm age. The range of age is 10 – 99 years.

Step 4: Set up User Height (H.t): Default 60 inches or last entered height will appear on the dot matrix window. Press ▲/▼key to adjust the height and ENTER key to confirm height. The range of height is 40 – 80 inches.

Step 5: Set up User Weight (W.t): Default 100 lbs or last entered weight will appear on the dot matrix window. Press ▲/▼key to adjust the weight and ENTER key to confirm weight. The range of weight is 40 – 350 lbs.

After weight is set up, the user profile set up is now completed and user information will be saved into selected user number permanently. To change the user information, simply go through the set up process and enter a different number.

b. **Program select:** After user profile is set up, it's time to pick a program category that you would like to workout on. There are 5 categories of programs: Manual, Program, Watt, Personal, H.R.C.

After user profile is set up, the program category names will all light up and flash at the same time. Press ▲/▼key to select a desired program category and ENTER to confirm.

To go back to the program category selection mode, simply press RESET key once; the console will reset back to selection mode.

c. **Manual program:** When ▲/▼key is pressed during category selection mode and Manual indicator is lit & flashing; press the ENTER key to enter Manual program.

i. Quick Start: If you press the START/STOP once either before or after ENTER key is pressed to confirm Manual program, the console will enter Quick Start program. The time will start counting up and resistance level will start with L1. Simply start pedaling and press ▲/▼key to adjust resistance level.

ii. Manual program: If you press ENTER key to confirm Manual program selection, the next step is setting up resistance level.

Dot matrix profile will light up the 1st row and Level display will flash with 1; press ▲/▼key to adjust the level from 1 to 16 and ENTER to confirm. You can also adjust the resistance anytime during program execution.

After level entry, time window will flash with 00:00 or last entered time; press ▲/▼key to adjust the time and ENTER to confirm. The range of time is 0:00 – 99:59 (min: sec).

After time entry, the Manual program set up is now completed; press START/STOP to begin this program.

Note: Manual program can also work as a goal training program for Distance; Calories & Pulse. (Pulse goal will work just like Target HR program). For the goal program set up; please make sure you only enter the value for the desired goal and enter 0 for other values. For example, enter 2.0 miles for Distance value and 0 for others; this will start the program as Distance goal program. The time will start counting up and the timer will stop when you reach the 2.0 mile goal.

Please keep in mind, if you enter multiple values during set up, it will work as a multiple goals program and whenever a goal is reached, the timer will stop.

d. **Program (Preset profile program):** When ▲/▼key is pressed during category selection mode and Program category name is lit & flashing; press the ENTER key to enter preset profile program. Press ▲/▼key to toggle through 12 preset programs; Dot matrix profile window will display program number P1-P12 and then flash its preset profile. Press ENTER to confirm the profile.

Below is the program profile detail:

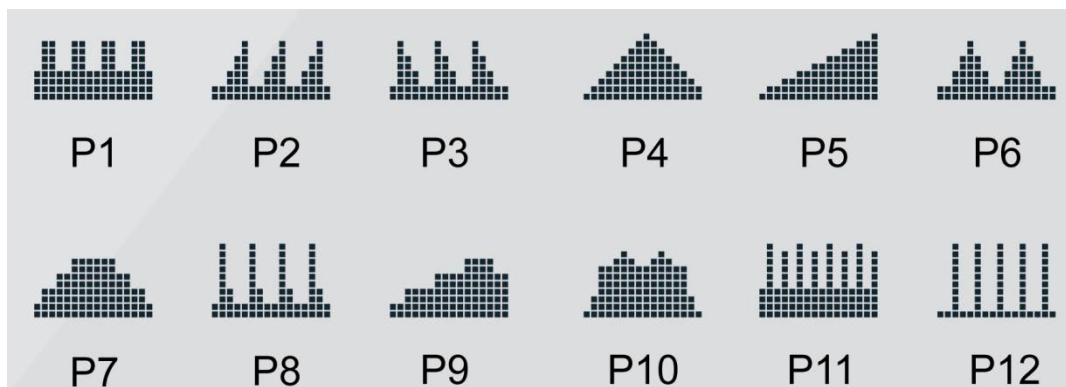

After you selected a desired profile; the next step is selecting a profile difficulty level. The dot matrix profile window will display the profile and Level window will light up appropriated level; press ▲/▼key to adjust the level and ENTER to confirm.

After level entry, time window will flash with 0:00 or last entered time; press ▲/▼key to adjust the time and press ENTER to confirm. The range of time is 0:00 – 99:59 (min: sec).

After time entry, the program set up is now completed; press START/STOP to begin this program.

e. **WATT program** (constant power program): Watt (power) is determined by speed & resistance. This program is designed to let you set up your watt goal. The console will automatically adjust the resistance level according to your speed to maintain your watt goal.

When ▲/▼key is pressed during category selection mode and WATT program name will light up & flash. Pressing the ENTER key will let you enter WATT program.

If you press the ENTER key to select the WATT program; the next step will be to set up your watt goal. The Watt/Calories window will flash 100 or last entered value; press ▲/▼key to adjust the value and ENTER to confirm. The range of watt is 10 – 350 and can only be adjusted in decimals of 5.

After watt entry, time window will flash with 0:00 or last entered time; press ▲/▼key to adjust the time and ENTER to confirm. The range of time is 0:00 – 99:59 (min: sec).

After time entry, the program set up is now completed; press START/STOP to begin this program.

f. **Personal program:** This program is designed for users to build the program profile segment by segment before exercising.

When ▲/▼key is pressed during category selection mode and Personal program name is lit & flashing; pressing the ENTER key will let you enter the User setting program.

Pressing ENTER key to select Personal program; the next step will allow you to set up the program profile. The 1st segment LCD on the dot matrix window will start blinking and waiting for an entry. Press ▲/▼key to adjust the level. Press the ENTER key to confirm and go to next segment and so on. Press the START/STOP key at anytime to start the program. The remaining segments will start with resistance level 1.

g. **H.R.C. program:** H.R.C. programs are based off of user profile information. Heart rate control programs are designed to keep you training at your chosen heart rate level. Console will adjust the resistance level automatically to ensure the target heart rate is achieved and maintained during the entire program.

Your target heart rate, the intensity needed to improve cardiovascular fitness, depends primarily on your age and not your state of fitness. It is calculated as a percentage of your maximum heart rate,

estimated as 220 minus your age. It is most effective to train at your target heart rate between 60% and 85% of your maximum heart rate. In order to get the most accurate reading, it is recommended to enter your age before your workout.

Note: A heart rate monitoring device must be used for the program to work. For better results, a chest strap is recommended for this operation. It is also important to consult your physician before performing any Heart Rate based training program.

When ▲/▼key is pressed during category selection mode and H.R.C. program category name is lit & flashing; press the ENTER key to enter H.R.C. programs. Press ▲/▼ key to toggle through 4 H.R.C. programs. An associated program indicator graphic will light up to show the selected heart rate program. Press ENTER to confirm the program.

4 H.R.C. programs & its indicator graphic:



TAG: Target HR



55%: 55% of max heart rate



75%: 75% of max heart rate



90%: 90% of max heart rate

i. TAG: Target heart rate program:

Press the ENTER key to select TAG program, then set up your heart rate goal. The Pulse window will blink with the pulse value; press ▲/▼key to adjust the value and ENTER to confirm. The range of pulse is 30 – 240.

After pulse entry, time window will flash with 0:00 or last entered time. Press ▲/▼key to adjust the time and ENTER to confirm. The range of time is 0:00 – 99:59 (min: sec). After time entry, the program set up is now completed. Press START/STOP to begin this program.

ii. 90%; 75% & 55% max heart rate program:

As described before, the max heart rate = 220 – age; these programs will calculate your target heart rate with your entered age & the percentage automatically based on user profile. When the program indicator is lit; its calculated heart rate will be displayed on the Pulse window.

If you press the ENTER key to select one of these 3 programs; the next step is setting up program time. Time window will flash with 0:00 or last entered time. Press ▲/▼key to adjust the time and ENTER to confirm. The range of time is 0:00 – 99:59 (min: sec). After time entry, the program set up is now completed. Press START/STOP to begin this program.

Note: During program execution, if your actual heart rate exceeds target heart rate for awhile; for safety reasons, the console will beep and stop the timer.

Monitoring Your Heart Rate

In order to obtain the greatest cardiovascular benefits from your exercise workout, it is important to work within your target heart rate zone. The American Heart Association defines this target as 60%-75% percent of your maximum heart rate.

Your maximum heart rate may be roughly calculated by subtracting your age from 220. Your maximum heart rate and aerobic capacity naturally decreases as you age. This will vary from one person to another. Use this number to find your approximate effective target zone. It is most effective to train at your target heart rate between 60% and 85% of your maximum heart rate; referred to as "Training Zone". In order to get the most accurate reading, it is recommended to enter your age before your workout.

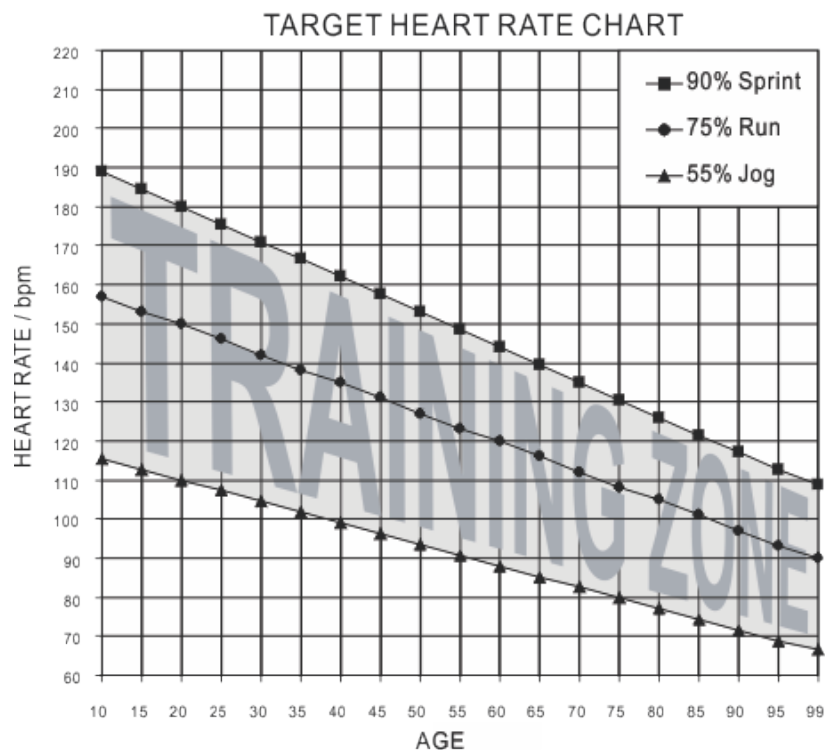

Before beginning your workout, check your normal resting heart rate. Place your fingers lightly against your neck or against your wrist over the main artery. After finding your pulse, count the number of beats in 10 seconds. Multiply the number of beats by six to determine your resting pulse rate per minute. We recommend taking your heart rate at these times; at rest, after warming up, during your workout and two minutes into your cool down, to accurately track your progress as it relates to better fitness.

During your first several months of exercising, the AHA recommends aiming for the lower part of the target heart rate zone-60%, then gradually progressing up to 75%. According to the AHA, exercising above 75% of your maximum heart rate may be too strenuous unless you are in top physical condition. Exercising below 60% of your maximum will result in minimal cardiovascular conditioning.

Check your pulse recovery rate – If your pulse is over 100bpm five minutes after you stop exercising, or if it's higher than normal the morning after exercising, your exertion may have been too strenuous for your current fitness level. Rest and reduce the intensity level of the next exercise.

Fitness Safety: *The Heart Rate chart indicates average heart rate zones for different ages. A variety of different factors (including medication, emotional state, temperature and other conditions) can affect the target heart rate zone that is best for you. Your physician or health care professional can help you determine the exercise intensity that is appropriate for your age and condition.*

Heart Rate Monitoring Devices

Pulse Hand Grips (Standard)

The 850RBs comes standard with stainless steel pulse handgrips. To activate, gently grasp both handgrips to obtain a heart rate reading.

Note: It is recommended to wear a chest strap for The Heart Rate control programs, as it is more accurate. If you wear a chest strap and use hand grips at the same time for heart rate monitoring purpose, please note; the console will take the measurement of the chest strap.

Operating Tips:

If you are not getting a consistent reading while using the hand pulse option, we recommend the following suggestions:

- Make sure that the palms of the hands are touching the contact area of each hand pulse grip.
- Maintain an even pressure on the grips.
- Do not hold the hand pulse grips too tightly.

Chest Strap (Optional)

The 850RBs is equipped with a built-in wireless receiver for your heart rate monitoring. Please contact your dealer for a compatible chest strap transmitter.

To get an accurate reading using these devices, you will need to be within three feet of the console, and a minimum of four feet from others using a heart rate monitoring device.

The receiver of the wireless ECG system is built into the console unit.

- (1) Buckle one end of the chest strap onto the transmitter.
- (2) Adjust the band length so that the fit is snug, but not too tight.
- (3) Buckle the other end of the chest strap onto the transmitter
- (4) Center the transmitter on your chest below the pectoral muscle (breasts).
- (5) Stretch the transmitter away from your chest and moisten the conductive electrode strips located next to the buckles with water.

Note: The transmitter is on automatically when being worn. It is off when it is not connected to your body. However, as moisture may activate the transmitter, thoroughly dry the transmitter to prolong battery life

Care and Maintenance

The LifeCore 850RBs is made from the best materials and has been tested and received a quality control review prior to its packaging to ensure the correct parts and proper fitting of each component. The amount of maintenance required is very little and very simple; however, a failure to implement preventative maintenance suggestions can prevent the machine from operating as designed. The 850RBs is only for indoor use and should not be stored in damp, extremely cold or hot areas as this will damage the unit this voiding the warranty.

Always inspect hardware prior to any exercise session. Look for loose hardware, loose pedals, loose cranks and frayed wires. Repair or replace any damaged or worn parts, tighten all loose hardware.

- Always clean the machine after use.
 - 1) Proper cleaning is important for longevity of a machine, clean the unit with a light soap water mixture, follows by a dry towel, or uses a light house hold cleaner such as Windex to remove dirt. The purpose of cleaning the unit is to remove body sweat which contains salt. Salt is the number one factor that will cause the unit to rust and the electronics to stop working.
 - 2) Dry the unit off with a clean towel to remove left over moisture after every use.
 - 3) To clean pads, use a mild soap and warm water.

- As part of LifeCore's normal installation and set-up process, all pedal cranks must be tightened after 8 to 10 hours of initial riding to ensure parts are properly seated to axle. This is standard initial "break-in" service, which must be performed after the first 8 to 10 hours of use. Un-tightened pedal cranks may become loose, causing damage, which may void the warranty.

- After the first 12 hours of use, check and retighten any bolts, nuts, screws, etc. making sure that they are tight and working properly.
 - 1) The number one service issue is loose hardware. Loose hardware can cause the unit to tick, creak, thump, knock, etc. After the first 12 hours once all the hardware has been tightened, the hardware should be checked every 3 months.

- Only use the appropriate power source, never use an adapter that is not certified for the unit, a wrong adapter will cause the electronics to overheat and malfunction.

In the unlikely event that the 850RBs experiences a problem, please contact LifeCore fitness for advice toll free at 888-815-5559.

Warranty Card

Limited Consumer Warranty

LifeCORE Fitness Inc.
LC-850RBS RECUMBENT BIKE

What is Covered. LifeCORE Fitness, Inc. ("LifeCORE") warrants to the original purchaser of this LifeCORE Fitness branded product (the "Product") that the frame of the Product shall be free from defect in materials and workmanship during the normal life of the Product and all other part and components of the Product shall be free from defect in material and workmanship for a period of 3 years when the Product is used under as recommended by LifeCORE under normal family household uses and conditions. During the warranty period LifeCORE will at no additional charge to you, repair or replace (at LifeCORE option) the frame or any part of the Product if it becomes defective, malfunctions, or otherwise fails to conform with this Limited Warranty. All labor for any required repair is warranted for 1 year from the date of original purchase. After one year all labor shall be the responsibility of the owner.

What is Not Covered. This Limited Warranty applies only for Product sold in the United States under the LifeCORE brand name. This warranty does not cover normal wear and tear on items such as, but not limited to, transportation wheels, foot pedals, rubber grips, plastic end caps, scratched parts, broken covers, cosmetic damage, and excludes paint & finish. Wear items pertain to components that might need to be replaced due to wear and tear resulting from normal usage. This warranty is void if the Product is improperly stored, installed, altered and/or modified in any way, misused, abused, is subject to accident, is improperly maintained, and this warranty does not cover repair for any noises such as: squeaks, clunks, thumps resulting from poor or lack of preventive maintenance. This Limited Warranty does extent to any Product that is damaged or rendered defective; (a) as a result of accident, misuse, or abuse; (b) use with the Product of any part not manufactured or sold by LifeCORE; (c) by modification of the Product; (d) by normal wear and tear; (e) operation using incorrect power supplies; or (f) as a result of service by anyone other than LifeCORE, or an authorized LifeCORE service provider. This Limited Warranty is void if the Product serial number has been defaced or removed. Should any Product be submitted for warranty service be found ineligible, an estimate of repair cost will be furnished.

Warranty Service Area. Any labor cost above the amount allocated by LifeCORE is the responsibility of the original purchaser. If a Product requires shipment, delivery or transport to an area that is not within a LifeCORE distribution area or is outside of a serviceable area is the purchaser's sole responsibility and to pay for any fees associated with servicing of a Product out of LifeCORE Fitness distribution or serviceable area. Any evidence of alteration, erasing or forgery of proof-of-purchase documents voids this Limited Warranty. This Limited Warranty applies only to Product purchased from LifeCORE or from an authorized LifeCORE reseller.

Disclaimed Warranties. TO THE MAXIMUM EXTENT ALLOWED BY LAW, ALL WARRANTIES, INCLUDING BUT NOT LIMITED TO EXPRESS WARRANTY, IMPLIED WARRANTY, WARRANTY OF MERCHANTABILITY, FITNESS FOR PARTICULAR PURPOSE AND WARRANTY OF NON-INFRINGEMENT OF INTELLECTUAL PROPERTY, ARE EXPRESSLY EXCLUDED TO THE MAXIMUM EXTENT PERMITTED BY LAW; AND LIFECORE NEITHER ASSUMES NOR AUTHORIZES ANY PERSON OR ENTITY TO ASSUME FOR IT ANY DUTY, OBLIGATION OR LIABILITY IN CONNECTION WITH ITS PRODUCTS. LIFECORE HEREBY DISCLAIMS AND HAS ABSOLUTELY NO LIABILITY FOR ANY AND ALL ACTS OF THIRD PARTIES INCLUDING DEALERS OR INSTALLERS. IN THE EVENT OF A CLAIM OR A DISPUTE INVOLVING LIFECORE OR ITS SUBSIDIARY, THE PROPER VENUE SHALL BE SAN DIEGO COUNTY IN THE STATE OF CALIFORNIA. CALIFORNIA STATE LAWS AND APPLICABLE FEDERAL LAWS SHALL APPLY AND GOVERN THE DISPUTE. THE MAXIMUM RECOVERY UNDER ANY CLAIM AGAINST LIFECORE SHALL BE STRICTLY LIMITED TO THE PURCHASE PRICE OF THE PART. LIFECORE SHALL NOT BE RESPONSIBLE FOR ANY DAMAGES WHATSOEVER, INCLUDING BUT NOT LIMITED TO, ANY CONSEQUENTIAL DAMAGES, INCIDENTAL DAMAGES, DAMAGES FOR THE LOSS OF TIME, LOSS OF EARNINGS, COMMERCIAL LOSS, LOSS OF ECONOMIC OPPORTUNITY AND THE LIKE.

Some states do not allow limitations on how long an implied warranty will last or the exclusion or limitation of incidental or consequential damages. This warranty gives you specific legal rights and you may also have other rights that vary from State to State. LifeCORE does not and has not authorized any person or entity to create for it any other obligation, promise, duty or obligation in connection with this Product.

Warranty Registration. PLEASE SEND IN THE ATTACHED WARRANTY CARD WITHIN (10) DAYS OF PURCHASE TO REGISTER YOUR PRODUCT WITH LIFECORE FITNESS. PLEASE MAIL WARRANTY CARD TO: LIFECORE FITNESS, INC, 2575 Pioneer Ave. Suite 101. Vista, CA 92081. Phone (760)599-4555, Fax (760) 946-7602 or register online at LifeCOREfitness.com, Customer Service: 888-815-5559. Unless otherwise prohibited by law, in order to validate the warranty this Product must have been registered through LifeCORE Fitness Inc., and/or a copy of the proof of purchase, transferred warranty letter, and serial number must be presented at time of service. If these items are not presented at the time of requesting parts or service LifeCORE Fitness Inc. will not cover any warranty.

Warranty Claim Processing. To obtain warranty service, you must contact the original place of purchase. LifeCORE may at its option may repair or replace any defective Product frame or parts with new or serviceable used parts that are equivalent in function to the original parts. All exchanged frames and parts replaced under this warranty will at the time of service become the property of LifeCORE. LifeCORE reserves the right to change manufacturers of any parts to cover any existing warranty. Any parts determined to be defective must be returned to LifeCORE to obtain warranty service. You must prepay any shipping charges, export taxes, custom duties and taxes, or any other charges associated with transportation of the parts or Product. In addition, you are responsible for insuring any parts or Product shipped or returned. You assume the risk of loss during shipment.

Please see other LifeCORE Fitness Products at www.LifeCOREfitness.com.

THANK YOU FOR YOUR BUSINESS!

LC-850RBs Recumbent Bike **Please Attach a Copy of the Original Receipt**

Full Name:

Address:

City: _____ State: _____ Zip Code: _____

Daytime Phone No.: _____ Cell Phone No.: _____

Email:

Dealer Purchased from: _____

Model: LC-850RBs Recumbent Bike Date Of Purchase: _____

Serial No. _____

Environment Placed: Residential Light Commercial Commercial



“We Fit Your Life”

Customer Service
Toll Free (888) 815-5559
Mon-Friday 7:30 - 5:30 PT
Service@lifecorefitness.com

Lifecore Fitness Inc.
2575 Pioneer Ave. Suite 101
Vista, CA 92081

Visit our website for assembly videos: www.lifecorefitness.com