



User's Product Manual



LifeCore LC-CD400 Center Drive Elliptical

Introduction

Congratulations on your purchase of the CD400 Center Drive Elliptical. This product has been designed and manufactured to meet the needs and requirements of domestic use.

By Choosing your CD400 Elliptical, you have made a wise decision that will improve the health of you and your family. Being fit and healthy will improve your energy level and your quality of life.

Cardiovascular training is vital for all ages and the CD400 Elliptical provides a more effective workout, producing better results, and will encourage you to reach your fitness goals and maintain the body you have always wanted.

In order to make your experience with LifeCore the best it can be, please review the enclosed user's manual prior to assembly and first use. Be sure to keep the instructions for reference and/or maintenance.

We also offer a complete line of fitness equipment; please take a moment to review our other excellent products at www.lifecorefitness.com. Should you have any questions, please contact us. Your feedback and ideas about your experience with LifeCore are also very important to us. Write to us at:

LifeCore Fitness Inc.
2575 Pioneer Ave. Suite 101
Vista, CA 92081

We wish you lots of success and fun while training!

Purchaser's Reference Information

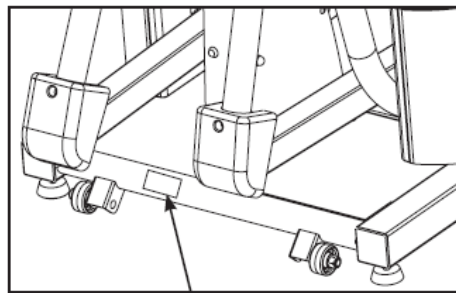

Serial Number is located on the frame

Please send in the attached warranty card and a copy of the original receipt or register online at www.lifecorefitness.com within (10) days of purchase to register your product with LifeCore Fitness.

Table of Contents

| | |
|---|----|
| Introduction..... | 1 |
| Purchaser's Reference Information | 1 |
| Table of Contents..... | 2 |
| Safety instructions and Warnings..... | 3 |
| Assembly Instructions | 4 |
| Console Operation Instructions | 12 |
| Monitoring Your Heart Rate | 18 |
| Heart Rate Monitoring Devices | 19 |
| Care and Maintenance | 20 |
| Warranty Card..... | 21 |



“We Fit Your Life”

Safety Instructions & Warnings

The CD400 Elliptical is designed and manufactured to meet or exceed all domestic and international safety standards. However, certain precautions need to be followed when operating any exercise equipment.

General safety instructions:

1. It is important to consult your physician before any exercise program.
2. Pregnant women should consult with their physician before beginning any exercise program. He/she can help determine the exercise program that is the most appropriate for your age and physical condition.
3. If you experience dizziness, nausea, chest pains or other abnormal symptoms during exercise, stop the exercise session immediately. Consult your physician before continuing your exercise.
4. Keep children away from the equipment. Hands and feet may get caught in the pedals or other moving parts, which could result in serious injury.
5. No more than one person should ever use the product at a time.
6. Pets should never be allowed near unit.
7. Always wear proper clothing and shoes when exercising. Drink plenty of fluids when exercising.
8. Always stretch and warm up before starting any exercise program.
9. Never operate this unit if it is damaged or broken. Contact your authorized dealer for service.
10. Place your equipment on a solid, level surface when in use.
11. Place your unit in an area with enough clearance to operate the equipment.
12. Make sure all components are fastened securely at all times.

Product safety instructions:

1. Start your exercise program gradually. Exercise only for a few minutes the first day to let your body adjust to the new exercise.
2. Slowly increase your exercise time and intensity over the first two weeks. If you increase your intensity too rapidly, or fail to warm up properly, you can increase the risk of injury.
3. Use of this machine with worn or weakened parts, may result in injury to the user. We strongly suggest replacing it immediately. Use only the accessory attachments recommended by the manufacturer.
4. Unit maximum weight limit is 350LBS
5. It is recommended the unit be plugged into a surge protector.
6. Whenever mounting or dismounting from the exercise machine, make sure that the unit is not in motion and use caution to prevent injury. Use the handlebars or a helper whenever additional stability is required.
7. Never place any open containers of any type directly on the unit, only containers with lids are recommended to be used with the appropriate water bottle holder.
8. Keep machine clear of any obstructions, heavy machinery, and never place objects on or against machine.
9. Do not place machine in an area of high voltage or electromagnetic fields.
10. DANGER: Always unplug the power cord before performing maintenance.
11. Failure to follow these instructions will void the units warranty and the manufacturer or distributor assumes no responsibility for personal injury or property damages related to the product if unit is ever used incorrectly or for reasons other than exercise.
12. Perform proper maintenance as recommended in this manual.
13. Save this manual for future reference.

Assembly Instructions

Assembly Tips

The LifeCore CD400 is made from the best materials and has been tested and received a quality control review prior to its packaging to ensure the correct parts and proper fitting of each component. This machine was designed to limit the amount of assembly needed by a consumer.

Before assembly of your product, distinguish a proper and appropriate location for the unit where there is easy access to an electrical outlet with a surge protector. Unpack the box in a clear work area to allow smooth assembly. Remove all of the parts from the packing material; however, do not discard packing material until assembly is complete. Double check packing materials to ensure no missing parts were left behind.

Note that some hardware may be preassembled to components in order to help with assembly; tools have also been provided to assist with assembly.

Assembly Assistance

In each CD400 assembly pack, there is a tube of grease for assembly purposes. This tube of grease must be applied to the pivot points during assembly. At no  time should this grease be applied on to the rubber wheels parts #2CUB Shaft Wheel w/ball bearing.

Figure 3 – Green Arrows



During Step 3 assembly, apply grease to the console tube pivot points  on each side. Once the arms are secure, apply some additional grease to the bearings, then secure arm with Figure 3 hardware.

Figure 5 – Green Arrows

During Step 5 assembly, apply grease to the pedal tube and handrail assembly tube pivot point  on each side. In addition, apply grease to the M10 * 81.5 Hex Bolt.

NOTE: DO NOT USE WD-40 OR SILICONE SPRAY – This will increase squeaking noise.

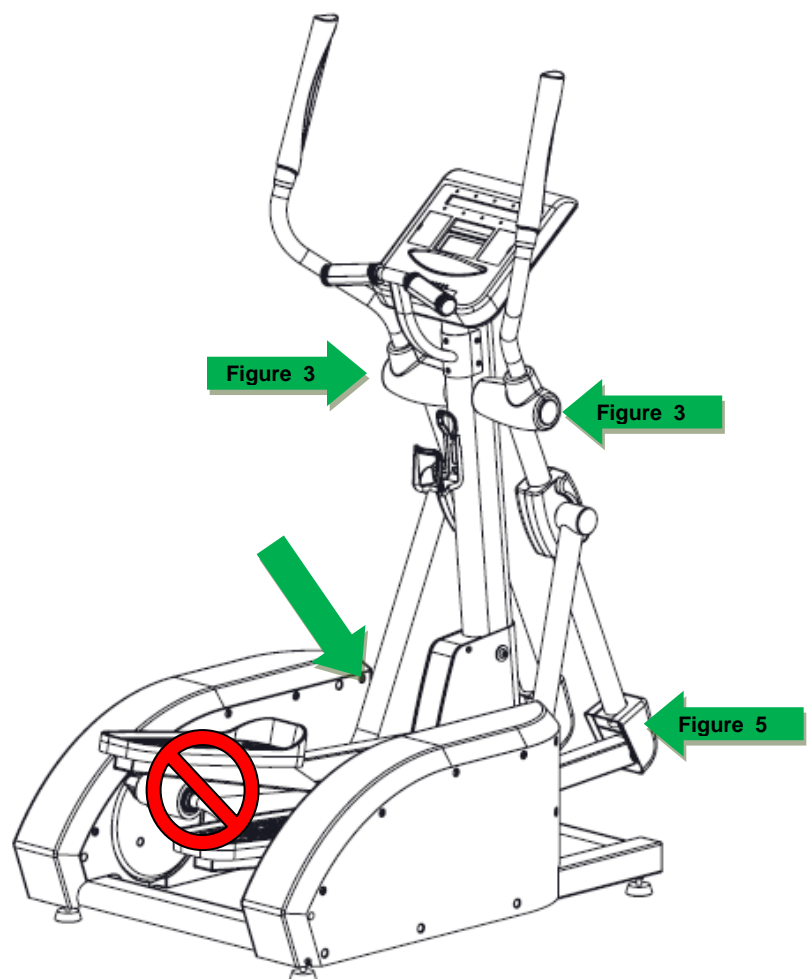

Getting Started

Unpack the box in a clear location, remove all packaged parts from the box and lay each part out on the floor. Double check all packaging material for missing pieces, do not dispose of any packing material until assembly is complete and unit is working properly. The final location of the machine should be placed on a clean level surface near an electrical outlet.

Hardware Bags - Locate all hardware bags for assembly. Bags will be labeled **Figure 1** through **Figure 11**. Tools have been provided to assist with product assembly.

If you are missing any parts, assembly bags or need assistance with assembly please call LifeCore Fitness at 1-888-815-5559.

Tools Required:

- 17 mm socket wrench: 2JAX
- 17 mm wrench: 2JAW
- Phillips screw driver: 2JAY
- 6mm Allen wrench: 2JC7
- 4mm Allen wrench: 0J3P
- Tube of grease: 2K81

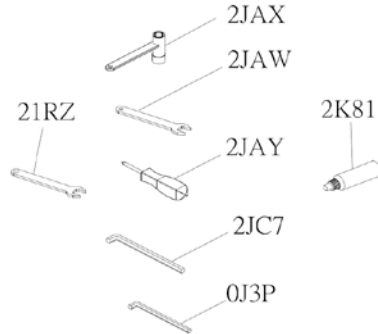

Step 1:

Tools Needed:

- 6mm Allen wrench: 2JC7
- 17 mm socket wrench: 2JAX

Note: Ensure that all wires are properly connected inside console tube. Be careful to not **pinch wires**. Additional help maybe needed to help line up holes to frame.

Note: Do not tighten screws until you have fully completed Step 2.

- 1) Locate bag labeled **Figure 1**.
- 2) Locate console tube.
- 3) Slide console tube into main frame.
- 4) **(See Figure 1)** Connect upper console wire to lead wire assembly coming from frame.
- 5) Secure console tube to frame using Qty. three 10x20 washers and three M10x80mm short hex head bolts and extend them through the holes on the right side of the frame and console tube. Use Qty. three M10x1.5 crown nuts to lock M10x80mm hex head screws on left side.
- 6) Use Qty. three M10x120 long hex bolts to secure console tube to the main frame.

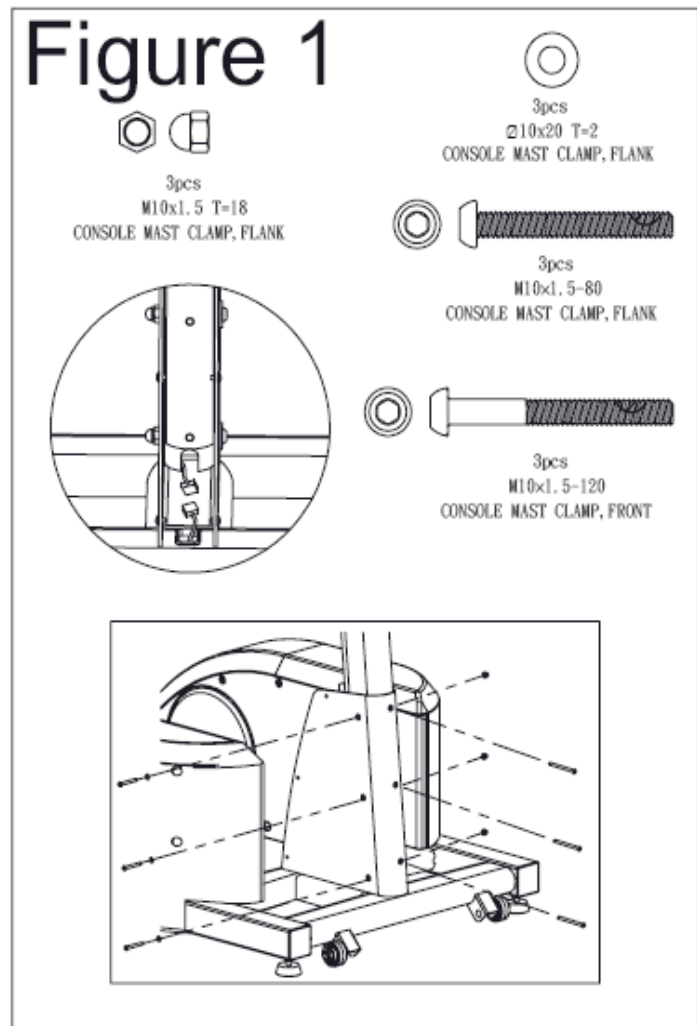

Step 2:

Tools Needed:

Philips Screw driver: 2JAY

- 1) Locate bag labeled **Figure 2**.
- 2) Locate black metal cover.

Note: First fasten screws at the bottom of the cover, next top and finally the middle.

- 3) (**See Figure 2**) Secure cover to main frame by using Qty. six M5x0.8-12 screws. Screw two at the bottom of the cover, next screw two on top and finally two in the middle. Using a Philips screw driver, tighten screws.
- 4) Tighten all hardware from **Step 1**.

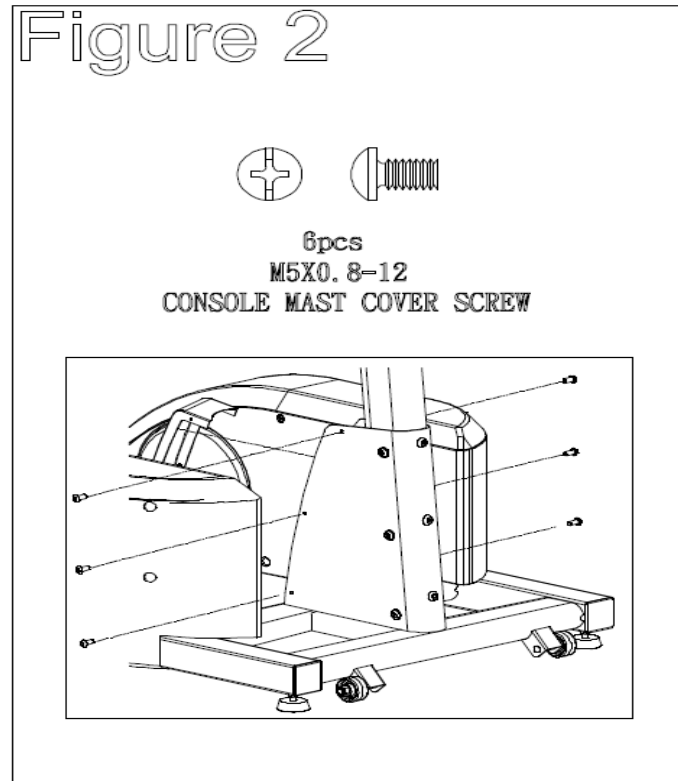

Step 3:

Tools Needed:

17 mm socket wrench: 2JAX

Tube of grease: 2K81

Note: Arms are labeled Right and Left.

Note: Apply about a finger tips worth of assembly grease on each pivot point shaft and bearings prior to connecting arms.

- 1) Locate bag labeled **Figure 3**.
- 2) Locate the left and right handrail assemblies.
- 3) (**See Figure 3**) Apply and spread grease on console tube shafts. Mount the left and right handrail assemblies to console tube using one washer first, one spring washer second and one M10*20 hex bolt last on each side. Using a 17 mm socket wrench, tighten hex bolts.

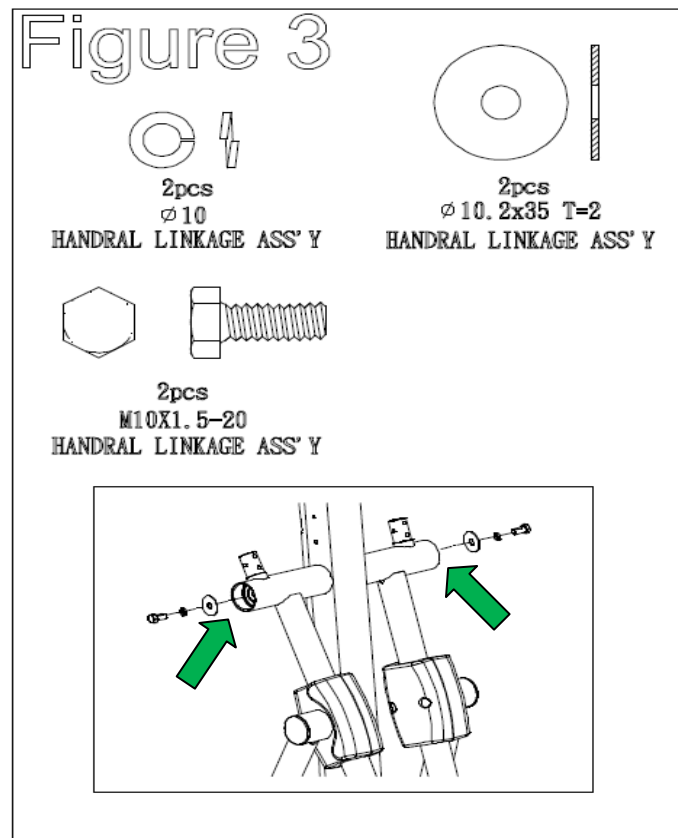

Step 4:

Tools Needed:

6mm Allen wrench: 2JC7

- 1) Locate bag labeled Figure 4.

Note: Additional help may be needed to help align holes on top and bottom.

- 2) (See Figure 4) Lift and place left linkage handrail assembly onto shaft sleeve. Make sure all four bolts line up. Screw Qty. two M8x12mm hex bolts to the top and bottom holes. Using a 6mm Allen wrench, tighten the bolts.

- 3) Repeat same steps for right side.

Step 5:

Tools Needed:

17 mm socket wrench: 2JAX

17 mm wrench: 2JAW

Tube of grease: 2K81

Note: It is recommended that two adults help align and secure the pedal tube assemblies to the handrail assemblies.

Note: Apply about a finger tips worth of assembly grease on each pivot point bolt shaft and bearings prior to connecting arms.

- 1) Locate bag labeled Figure 5.

Note: Please ensure that pedal arm is aligned in the center of roller wheel while tightening all hardware. Repeat for the left side.

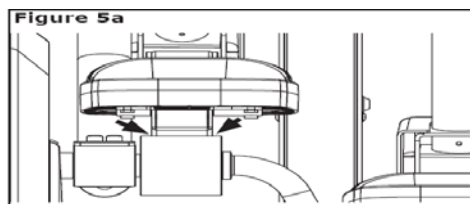

- 2) (See Figure 5) Locate right pedal tube assembly and secure to the handrail assembly with Qty. one M10x81.5 hex bolt and Qty. one M10x1.5 hex nut. Using a 17 mm socket wrench & 17 mm wrench, tighten the bolts.

Figure 4

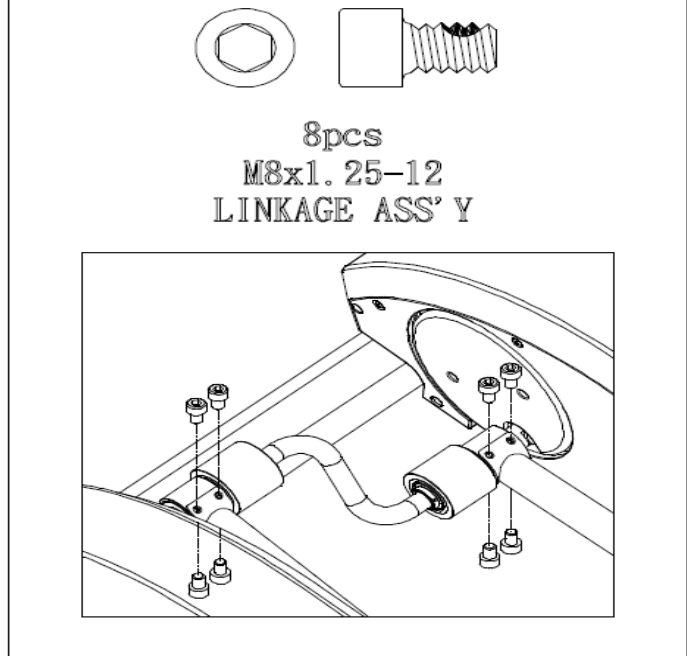
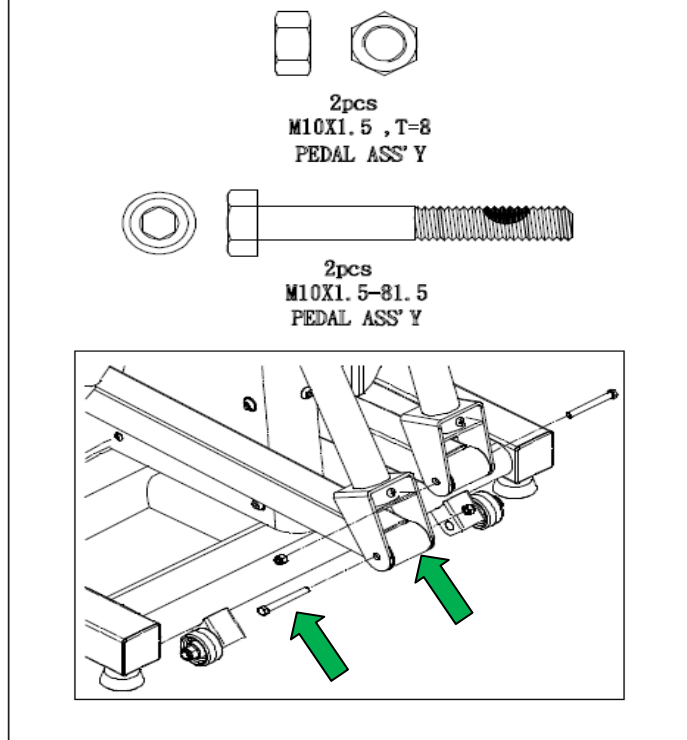

Figure 5



Step 6:

Tools Needed:

Philips screw driver: 2JAY

Note: Do not over tighten M5X0.8-12 screw, this will damage bracket cover.

- 1) Locate bag labeled **Figure 6**.
- 2) Locate bracket covers.
- 3) (**See Figure 6**) Attach bracket cover to the handrail assembly by lining up the hole and using a Philips screw driver to tighten Qty. one M5X0.8-12 screw into handrail assembly. Repeat for other side.

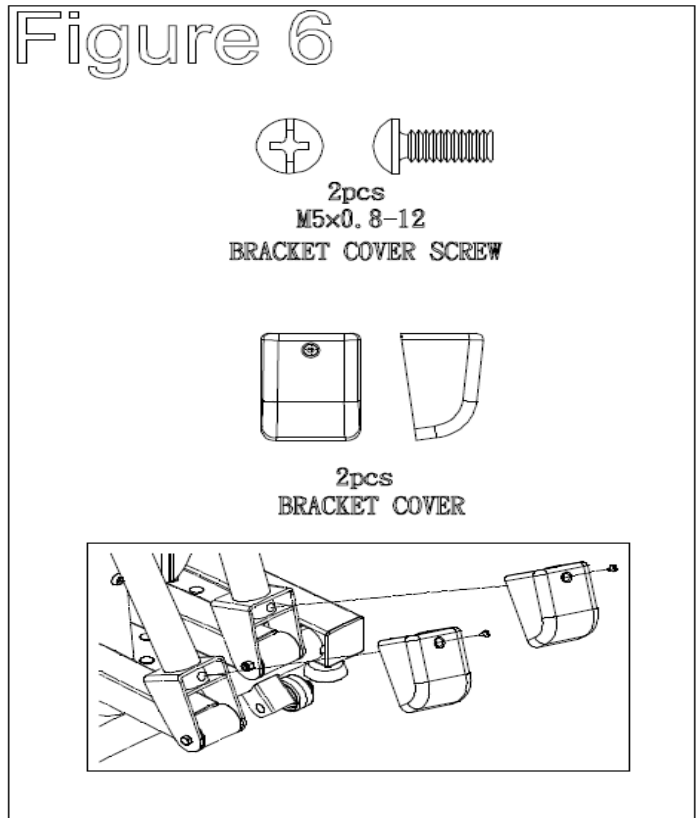

Step 7:

Tools Needed:

6mm Allen wrench: 2JC7

- 1) Locate bag labeled **Figure 7**.
- 2) Locate left and right handle bars.
- 3) (**See Figure 7**) Attach left handlebar to handlebar assembly using Qty. three M8X16mm hex bolts. Using a 6mm Allen wrench, tighten hex bolts tight.
- 4) Repeat for other handlebar.

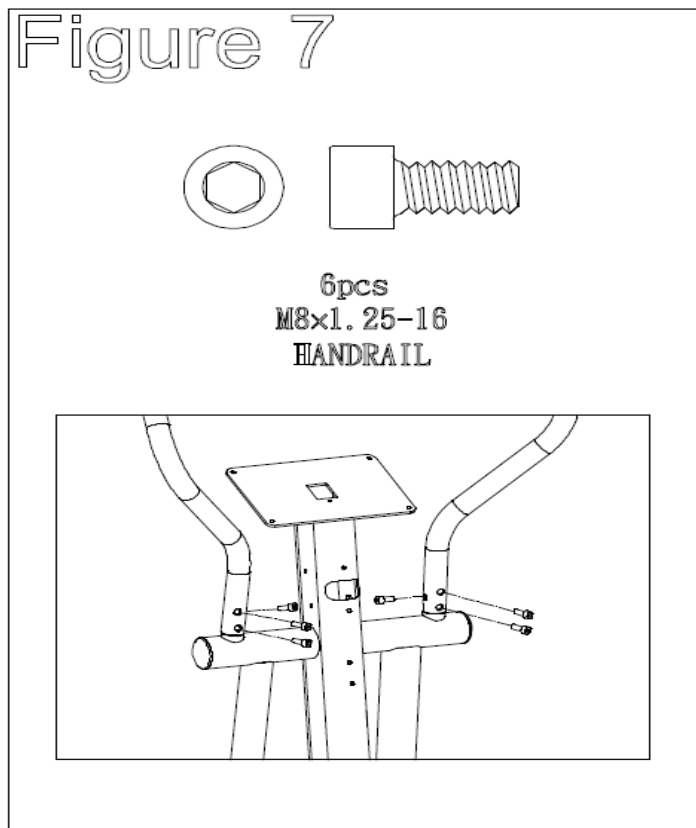

Step 8:

Tools Needed:

Philips screw driver: 2JAY

Note: Ensure that all wires are properly connected inside the console. Be careful not to pinch the wires. Wires only connect one way.

- 1) Locate bag labeled **Figure 8**.
- 2) Locate computer console.
- 3) **(See Figure 8-1)** Connect the white tip 7 pin computer cable wire into the white 7 pin connector on the board. Locate the green ground wire and connect it to the grounding terminal to the left of the white 7 pin connector on computer console. Locate the red 3 pin heart rate cable and black heart rate ground wire. Connect the red 3 pin wire to the red 3 pin connector on the board. Connect the black heart rate ground wire to the grounding terminal to the left of the 3 pin connector on the board.
- 4) Place the computer console on the console mast. Make sure the wires fit inside the computer and computer console sits flat on the console mast.
- 5) **(See Figure 8)** Secure four screws to the back of the console using a Philips screw driver. Tighten screws.

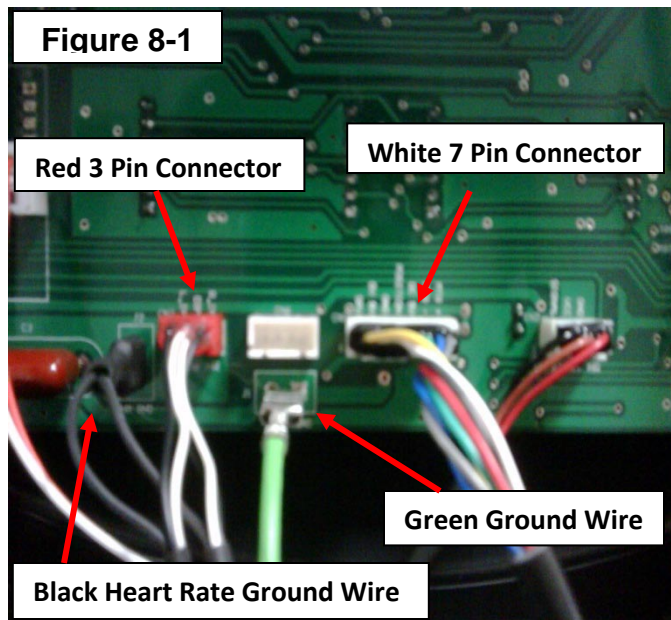
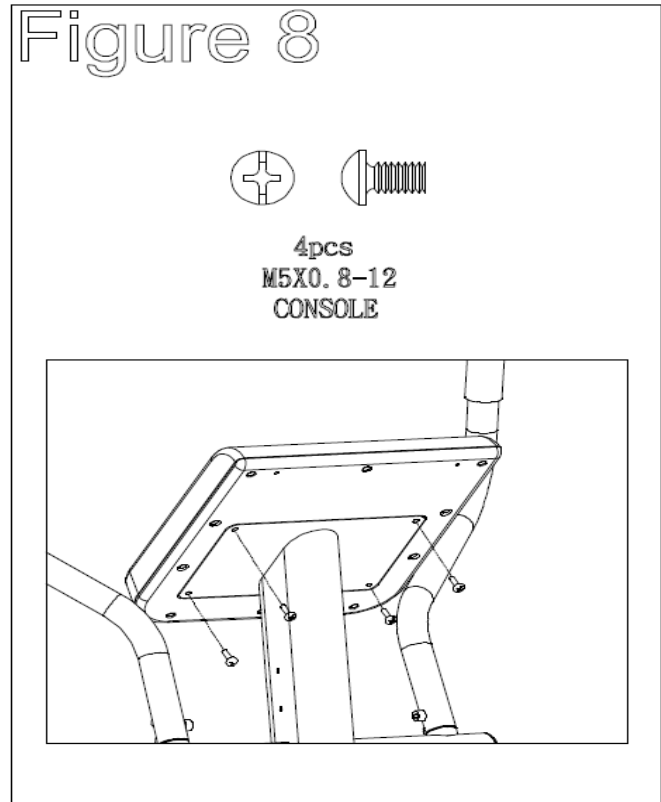

Step 9:

Tools Needed:

4mm Allen wrench: 0J3P

Note: Ensure that all wires are properly connected inside console tube. Be careful to not **pinch wires**. Addition help maybe needed to help line up holes to frame.

- 1) Locate bag labeled **Figure 9**.
- 2) (See **Figure 9**) Connect the pulse wires coming from the pulse handlebar assembly into the pulse wires from the console tube.
- 3) Secure the pulse handlebar assembly to the console tube by screwing Qty. six M6x10 hex socket head bolts into frame. Using a 4mm Allen Wrench, tighten bolts.

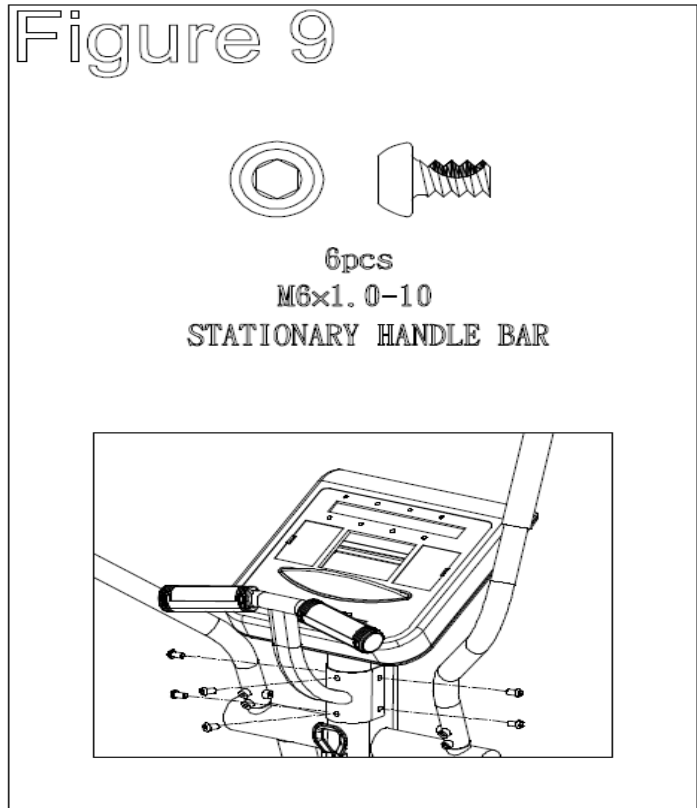

Step 10:

Tools Needed:

Philips screw driver: 2JAY

- 1) Locate bag labeled **Figure 10**.
- 2) Locate black pivot covers.
- 3) (**See Figure 10**) Connect the left side two pivot covers on to the handlebar assembly. Using a Philips screw driver, tighten Qty. two M4x16-10 screws from the front of machine.
- 4) Connect the right side two pivot covers and tighten screws from the back of machine.

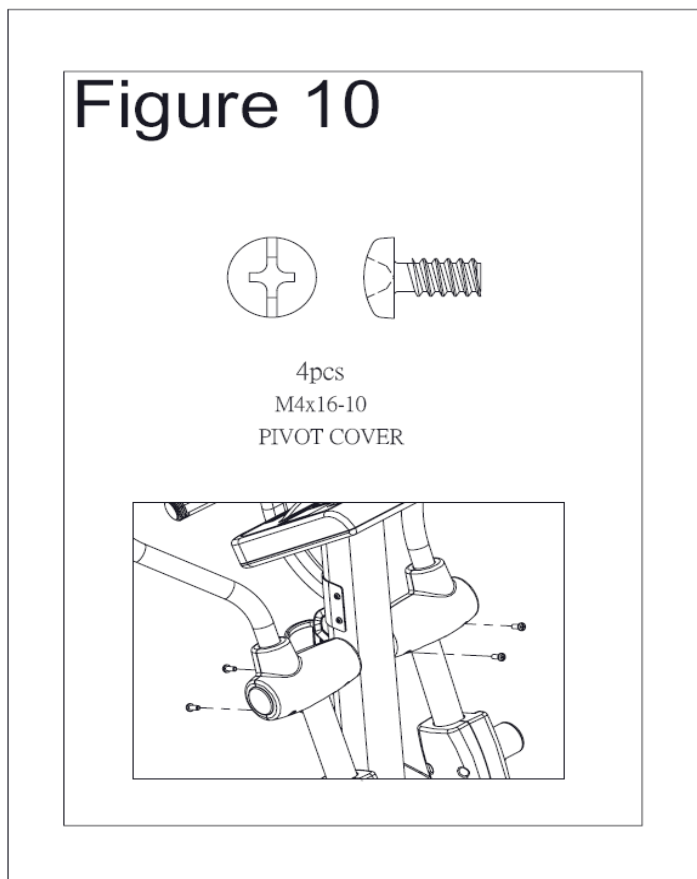

Step 11:

Tools Needed:

Philips screw driver: 2JAY

- 1) Locate bag labeled **Figure 11**.
- 2) (**See Figure 11**) Secure bottle holder to console tube using Qty. two M5x0.8-12 screws. Use a Philips screw driver to tighten.

Plug the AC adaptor into a power outlet and into the machine. The AC inlet is located on the user left side of the machine. Only a **DC 9V 1000mA** that comes with the unit should ever be used to power the machine.

AC Adaptor Location

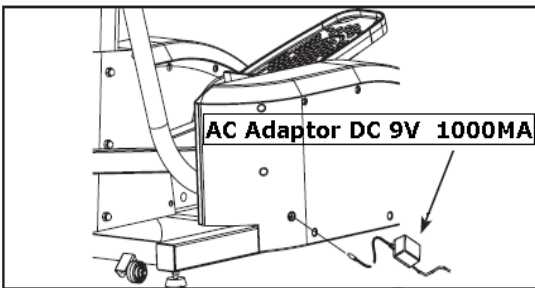

Once assembly is complete; if needed, tighten or loosen the levelers on the bottom with a 17mm wrench: 2JAW to prevent the machine from wobbling and to make the machine stable. Tighten the leveler nut on top of the lever to prevent them from moving.

Figure 11

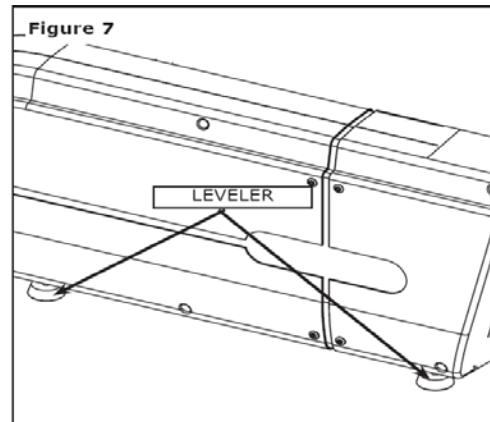
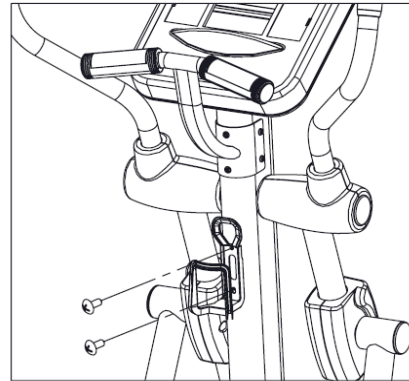
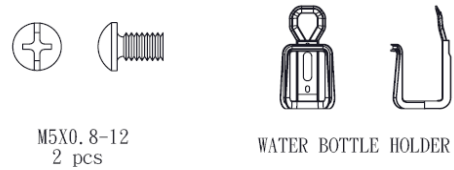

Congratulations!

You have completed assembly of your CD400 Elliptical

Console Operation Instructions

Please read the console operation instruction thoroughly and get familiar with the console layout. Practice using this console before you start in order to get a better understanding of the functions. Below is the console layout and detailed operation instructions.

Make sure the console is powered-up before you start using this console. This product is powered by an AC adapter. The LED will be fully lit and ready for an entry. If the LED display is illegible or only partial segments are displayed; then reboot the console. Disconnect the power for approximately 15 seconds and connect it again.

1. CONSOLE LAYOUT

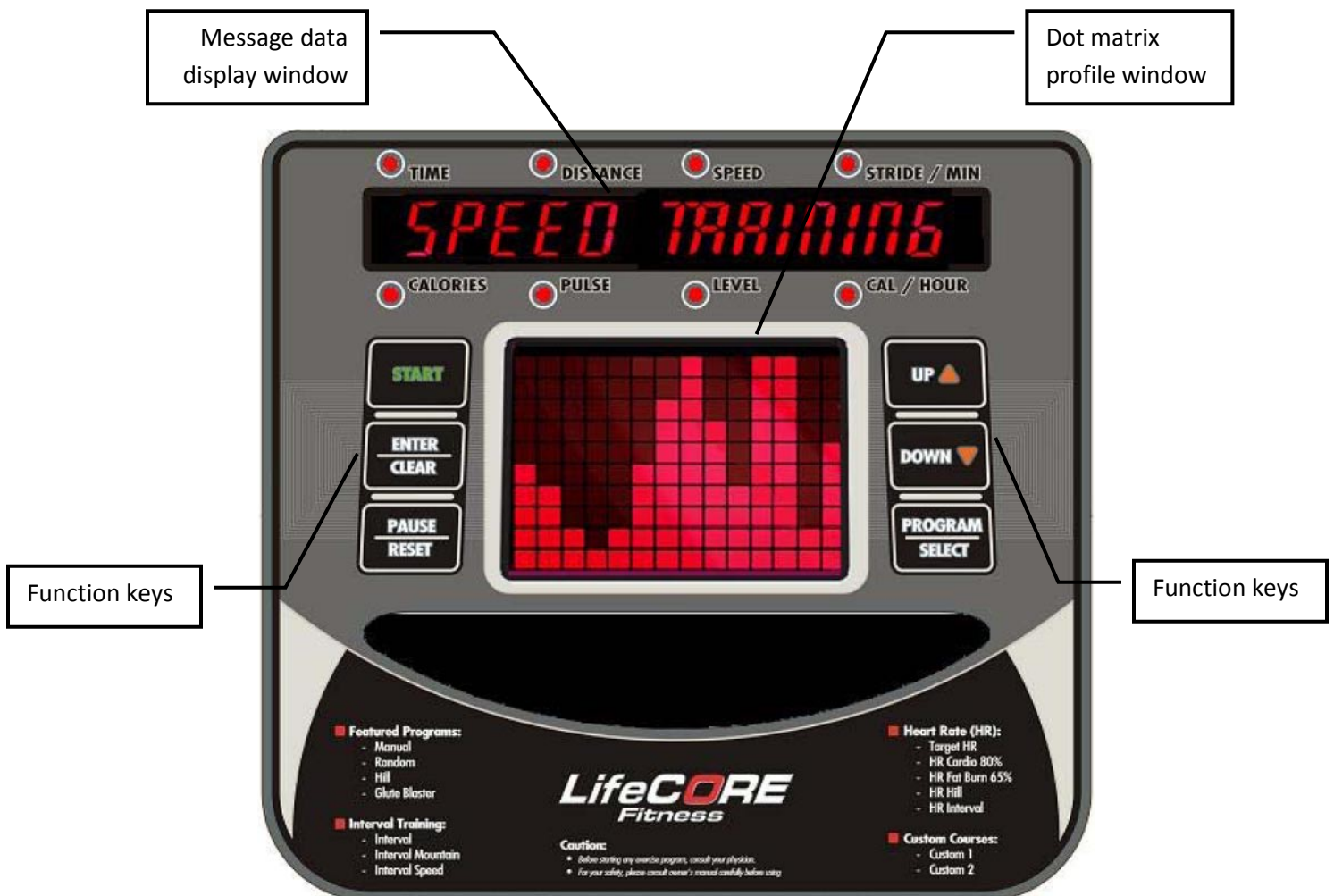

2. DISPLAYS

If no key is pressed, no RPM or pulse is detected for 4 minutes; the console will shut down and enter “power save mode” to save power. To resume, simply press a key again.

a. Dot matrix profile window: Displays program profile, heart rate bar (HR programs only), lap progress display and lap counter. The profile window toggles between program profiles every 10 seconds and lap counter every 30 seconds in the profile window, except for when a user is in Heart Rate programs, it will stay displaying lap progress.

Note: When changing resistance levels in preset programs, the change will not show in the program profile. Changes in resistance will display in lap progress displays in the first column.

Lap progress display – The lap progress displays for 30 seconds, after this time the selected program (example: Hill Program) will display for 10 seconds and will continue to alternate. Lap progress displays show a user’s progress around a virtual track. One dot on the virtual track counter is equal to 15 revolutions. One revolution is equal to 2 steps. A user’s current position on the virtual track will blink.

The resistance level will be displayed in the first column. Every dot in the tension column will represent an increment of one or two resistance levels. Resistance level goes from Level 1 to 20.

Lap display/Counter – When one lap has been completed in the virtual track, the amount of laps completed will display in the center of the virtual track. After one lap is completed, the lap progress will start again but the lap counter will continue.

When a heart rate mode program is selected by a user, the % of Maximum Heart Rate will display next to the tension level column.

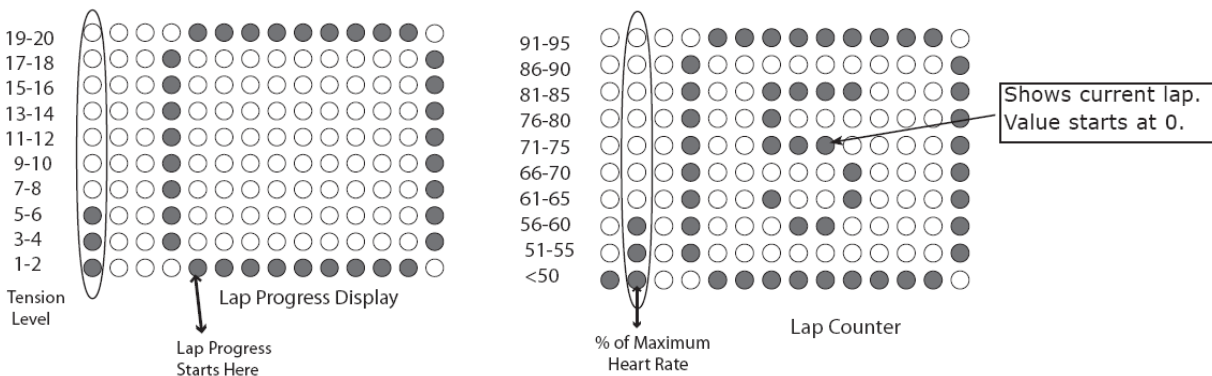

b. Message Data display windows: It displays program name, messages during program setting and executing. It is also used as data displays and displaying 8 data during program executing: Time, Distance, Speed, Strides/Min, Calories, Pulse, Resistance Level and Cal/Hour. There are associated LED indicators will light up to show you which data are being displayed.

3. **KEYS:** There are 6 function keys for program operation.

a. **START:** Pressing the START key once will execute the programs. Once a program has been selected, pressing the START key will activate the time and all data will start counting.

b. **ENTER/CLEAR key:** Press ENTER key to confirm the program setting, selection or data entry.

c. **PAUSE/RESET key:** Pressing the PAUSE/RESET key once will enter program pause mode and all data will stop counting. To exit pause mode, simply press START key to resume program. Press PAUSE/RESET key again after program is paused; it will reset the console back to beginning.

Press and hold PAUSE/RESET key for a few seconds to change the console units setting. Use UP/DOWN key to change the setting from English to Metric; once change is done, press ENTER/CLEAR key to confirm the setting.

d. **UP/DOWN key:** Press the UP/DOWN key to go to the next user profile setting; next program selection; adjusting data entry during program setting or level adjusting during program execution. Press down these keys for a few seconds; it will rapidly increase/decrease the values.

e. **PROGRAM/SELECT:** Press the PROGRAM/SELECT key to select between different programs. User may change the program selection during an exercise session by pressing the PROGRAM/SELECT key until a new program is selected. The new selected program will start from the beginning of the profile. All workout data will continue to add to previous values.

4. **PROGRAMS:**

There are 6 preset programs and 5 Heart Rate programs. The message window will display "PRESS PROGRAM KEY TO BEGIN"; press PROGRAM/SELECT key to pick a desired program. Once a program is displayed, press the ENTER/CLEAR key to confirm.

a. **Program setup:**

After a program is selected and entered, the message display will prompt messages for step by step program setup.

1) **Time setup:** Message display will show the default time: 30 minutes; press UP/DOWN key to adjust the time and ENTER/CLEAR key to confirm. The range of time allowed is 1 – 99 minutes. There are 14 columns of dot matrix representing 14 segments of time; each segment time = total program time divided by 14 columns. During exercising, a column of LED will blink to indicate the time segment you are currently in and show your workout progress.

2) **Weight setup:** Once time has been entered, weight setting will be shown on the message display. Press UP/DOWN key to adjust the weight and ENTER/CLEAR key to confirm. The range of weight allowed is 70 – 330 lbs.

3) **Age setup:** Once weight has been entered, age setting will be shown on the message display. Press UP/DOWN key to adjust the age. After you adjust the age, the program setup is completed;

press ENTER/CLEAR key at this time will confirm the age entry and begin workout. The range of age allowed is 10 – 99.

b. Quick Start:

When the message window displays “PRESS PROGRAM KEY TO BEGIN”, press the START key once will jump start the manual program with default values. The time will start counting down from 30 minutes and the resistance level will start with L1. The resistance level can be changed anytime during the workout by pressing the UP/DOWN keys to change from L1 - 20.

c. Manual program:

This program allows the user to control his/her workout more accurately than a Quick Start by entering his/her age, weight for calorie reading. The resistance level can be changed anytime during the workout by pressing the UP/DOWN keys to change from L1 - 20.

d. Preset profile programs:

There are 6 preset profile programs for you to select: Random, Hill, Glute Blaster, Interval, Interval Mountain and Speed Training Interval.

Below are the program profile details:

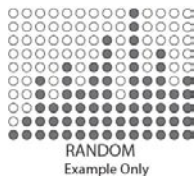

Random: The console will randomly generate a workout program every time a user chooses this program. If the program that is displayed does not fit the user’s liking, simply press PROGRAM/SELECT to scroll thru the programs until you get back to the Random program and a different program will be displayed.

This program provides endless program possibilities to keep workouts fresh, motivating and challenging.

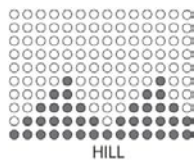

Hill: It will gradually take a user thru two hills. The resistance is moderate and will bring the resistance up and back down twice.

This is a good program to get started or for someone looking for a lower stress workout.

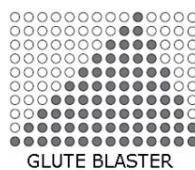

Glute Blaster: It will gradually take a user to the highest resistance peak, then gradually bring the tension level back to the beginning resistance level. This program best simulates a mountain climb.

This is a good program for people who want to reach higher tension levels over long periods of time, or who want to elevate his/her heart rate.

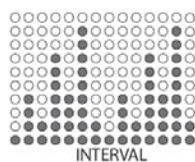

Interval: This program simulates very different interval training of resistance thru a series of two hill profiles.

Note: Lower intensity levels can provide effective fat burning.

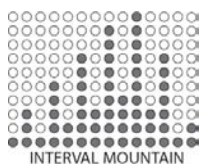

Interval Mountain: This program simulates gradually progressive interval training where the magnetic resistance gradually increases and decreases.

Note: Higher intensity levels can provide effective cardiovascular training.



Speed Training Interval: This program simulates interval training with more extreme levels of high and low magnetic resistance levels.

Note: Higher intensity levels can provide effective cardiovascular training.

e. User profiles:

Before picking a program to start; it's recommended to set up your user profile first. It will ensure workout data calculation is more accurate and future workouts are more convenient. There are 2 user spaces for saving user profiles: U1 & U2; user information such as Time, Age and Weight will be saved permanently unless user changes it.

During program selection mode, press PROGRAM/SELECT key until U1 or U2 is displayed in the dot matrix profile window and "EMPTY PROFILE – PRESS ENTER TO BUILD A NEW PROFILE" is in the message window. Press the ENTER/CLEAR key to select the user program and enter User setup. Message display will prompt messages for step by step user setting. Press the UP/DOWN key to adjust the value and the ENTER/CLEAR key to confirm. After age setting is adjusted and ENTER/CLEAR key is pressed, the program is set. Now the PROGRAM/SELECT key can be pressed to scroll thru the programs.

How User Profiles are used: Upon starting the unit, please press the PROGRAM/SELECT key until "User 1" or "User 2" is displayed in the profile window. Press ENTER/CLEAR then START to retrieve your "Custom Settings", then press the PROGRAM/SELECT key until the desired program is displayed in the message window. Afterwards, press START key to begin your workout.

User Profile Delete/Edit: Press the PROGRAM/SELECT key until "U1" or "U2" is displayed in the profile window. Press the ENTER/CLEAR key to select a User program; then follow the User Profile Setup to edit User 1 or 2. To reset the User profile back to 0, simply Press the ENTER/CLEAR, then Press and Hold the PAUSE/RESET key until the computer beeps and the message window displays "EMPTY PROFILE – PRESS ENTER TO BUILD A NEW PROFILE." The User profile is now reset.

f. Heart Rate programs:

Heart rate control programs are designed to keep you training at your chosen heart rate level. Console will adjust the resistance level automatically to ensure the target heart rate is achieved and maintained during the entire program. If no Heart Rate signal is detected for 10 seconds, the message window will show "NO DETECTED HR". If this continues for 40 seconds, the message window will show "ABORT PROGRAM" for 3 seconds it will then interrupt the Heart Rate Control program and return to Program Mode.

The console will check the user's heart rate every 40 seconds and adjust the resistance level to maintain the heart rate goal. The message display will show messages to indicate your program progress:

If your heart rate is within 5bpm to the target heart rate, the resistance will stay the same and message display will show "IN HR TARGET" for 3 seconds, then it will toggle back to workout information. If your heart rate is 5bpm less than target heart rate, the resistance will increase.

If your heart rate is 5bpm more than target heart rate, the resistance will decrease. If the current resistance is already at level 1, then message display will show "STRIDE SLOWER" for 3 seconds.

Note: A wireless heart rate monitoring device must be used for the program to work. It is also important to consult your physician before performing any Heart Rate based training program.

There are 5 Heart Rate Control programs: % Target Heart Rate, HR 80% Cardio, HR 65% Fat Burn, HR Hill 65% – 75% – 85% and HR Interval. Below are the program details:

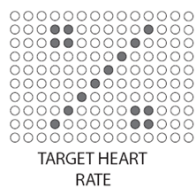

% Target Heart Rate: Allows the users to select their own percentage of maximum heart rate that you would like to maintain during your exercise session. The range of percentages is 50% to 85%. (See section titled MONITORING YOUR HEART RATE for more information)

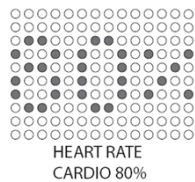

HR 80% Cardio: Maintains your target heart rate at 80% of max heart rate by automatically adjusting the tension levels to maintain that percentage. This is a good program for people who want to have a high intensity, cardiovascular workout.

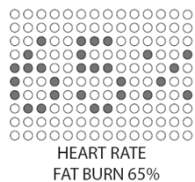

HR 65% Fat Burn: Maintains one's target heart rate at 65% of max heart rate by automatically adjusting the tension levels to maintain that percentage. This is a good program for people who want a fat burning workout.

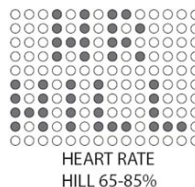

HR Hill 65%-75%-85%: Simulates hill training by changing the target heart rate thru three different percentages during the workout. The changes will occur as follows: 65% - 75% - 85% - 75% - 65% -75% - 85% etc. Each percentage will be held for three minutes before changing to the next percentage.

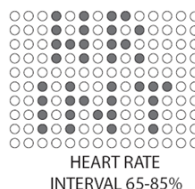

HR Interval: This program alternates between 65% and 85% of your max heart rate. This program provides an excellent fat burning and cardiovascular workout. Each percentage will be held for four minutes before alternating to the next percentage.

Monitoring Your Heart Rate

In order to obtain the greatest cardiovascular benefits from your exercise workout, it is important to work within your target heart rate zone. The American Heart Association defines this target as 60%-75% percent of your maximum heart rate.

Your maximum heart rate may be roughly calculated by subtracting your age from 220. Your maximum heart rate and aerobic capacity naturally decreases as you age. This will vary from one person to another. Use this number to find your approximate effective target zone. It is most effective to train at your target heart rate between 60% and 85% of your maximum heart rate; referred to as "Training Zone". In order to get the most accurate reading, it is recommended to enter your age before your workout.

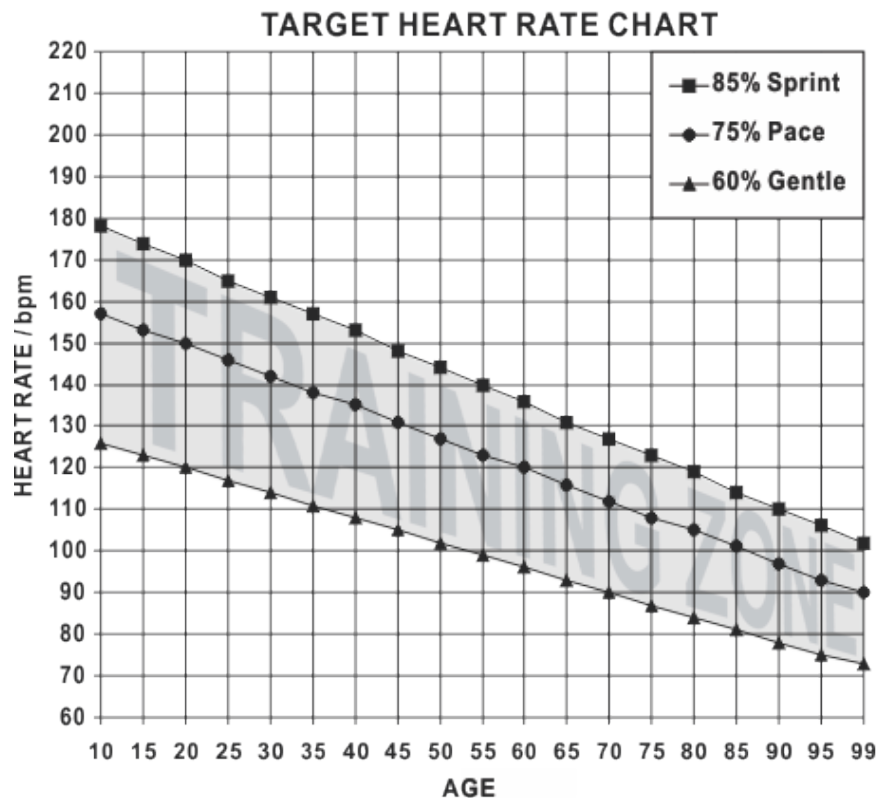

Before beginning your workout, check your normal resting heart rate. Place your fingers lightly against your neck or against your wrist over the main artery. After finding your pulse, count the number of beats in 10 seconds. Multiply the number of beats by six to determine your resting pulse rate per minute. We recommend taking your heart rate at these times; at rest, after warming up, during your workout and two minutes into your cool down, to accurately track your progress as it relates to better fitness.

During your first several months of exercising, the AHA recommends aiming for the lower part of the target heart rate zone-60%, then gradually progressing up to 75%. According to the AHA, exercising above 75% of your maximum heart rate may be too strenuous unless you are in top physical condition. Exercising below 60% of your maximum will result in minimal cardiovascular conditioning.

Check your pulse recovery rate – If your pulse is over 100bpm five minutes after you stop exercising, or if it's higher than normal the morning after exercising, your exertion may have been too strenuous for your current fitness level. Rest and reduce the intensity level of the next exercise.

Fitness Safety: The Heart Rate chart indicates average heart rate zones for different ages. A variety of different factors (including medication, emotional state, temperature and other conditions) can affect the target heart rate zone that is best for you. Your physician or health care professional

can help you determine the exercise intensity that is appropriate for your age and condition.

Heart Rate Monitoring Devices

Pulse Hand Grips (Standard)

The CD400 comes standard with stainless steel pulse handgrips. To activate, gently grasp both handgrips to obtain a heart rate reading.

Note: It is recommended to wear a chest strap for the Heart Rate control programs, as it is more accurate. If you wear a chest strap and use hand grips at the same time for heart rate monitoring purpose, please note the console will take the measurement of the chest strap.

Operating Tips:

If you are not getting a consistent reading while using the hand pulse option, we recommend the following suggestions:

- Make sure that the palms of the hands are touching the contact area of each hand pulse grip.
- Maintain an even pressure on the grips.
- Do not hold the hand pulse grips too tightly.

Chest Strap (Optional)

The CD400 is equipped with a built-in wireless receiver for your heart rate monitoring. Please contact your dealer for a compatible chest strap transmitter.

To get an accurate reading using these devices, you will need to be within three feet of the console, and a minimum of four feet from others using a heart rate monitoring device.

The receiver of the wireless ECG system is built into the console unit.

How to Wear Your Sensor/ Transmitter:

- (1) Buckle one end of the chest strap onto the transmitter.
- (2) Adjust the band length so that the fit is snug, but not too tight.
- (3) Buckle the other end of the chest strap onto the transmitter
- (4) Center the transmitter on your chest below the pectoral muscle (breasts).
- (5) Stretch the transmitter away from your chest and moisten the conductive electrode strips located next to the buckles with water.

Note: The transmitter is on automatically when being worn. It is off when it is not connected to your body. However, as moisture may activate the transmitter, thoroughly dry the transmitter to prolong battery life.

Care and Maintenance

The LifeCore CD400 is made from the best materials and has been tested and received a quality

control review prior to its packaging to ensure the correct parts and proper fitting of each component. This machine was designed to limit the amount of assembly needed by a customer. The amount of maintenance required is very little and very simple; however, a failure to implement preventative maintenance suggestions can prevent the machine from operating as designed. The CD400 is only for indoor use and should not be stored in damp, extremely cold or hot areas as this will damage the unit this voiding the warranty.

Rules:

- **Never** use WD-40 or any type of silicone spray to lubricate any moving parts. Use appropriate lithium assembly grease as needed to the pivot points if noise occurs.
- Always clean the machine after use.
 - 1) Proper cleaning is important for longevity of a machine, clean the unit with a light soap water mixture, follows by a dry towel, or uses a light house hold cleaner such as Windex to remove dirt. The purpose of cleaning the unit is to remove body sweat which contains salt. Salt is the number one factor that will cause the unit to rust and the electronics to stop working.
 - 2) Dry the unit off with a clean towel to remove left over moisture after every use.
- After the first 12 hours of use, check and retighten any bolts, nuts, screws, pedals, etc. making sure that they are tight and working properly.
 - 1) The number one service issue is loose hardware. Loose hardware can cause the unit to tick, creak, thump, knock, etc. After the first 12 hours once all the hardware has been tightened, the hardware should be checked every 3 months.
 - 2) Apply multi-purpose grease onto the bottom of both foot pedal tubes in the area that makes contact with the roller wheel. (Parts # 2CU8 Shaft Wheel w/ball bearing) This allows the wheel to roll smooth on the pedal tube.
- Only use the appropriate power source, never use an adapter that is not certified for the unit, a wrong adapter will cause the electronics to overheat and malfunction. AC Adaptor DC 9V 1000MA

In the unlikely event that the CD400 experiences a problem, please contact LifeCore fitness for advice toll free at 888-815-5559.

Warranty Card

Limited Consumer Warranty

**LifeCORE Fitness Inc.
LC-CD400 CENTER DRIVE ELLIPTICAL**

What is Covered. LifeCORE Fitness, Inc. ("LifeCORE") warrants to the original purchaser of this LifeCORE Fitness branded product (the "Product") that the frame of the Product shall be free from defect in materials and workmanship during the normal life of the Product and all other part and components of the Product shall be free from defect in material and workmanship for a period of 5 years when the Product is used under as recommended by LifeCORE under normal family household uses and conditions. During the warranty period LifeCORE will at no additional charge to you, repair or replace (at LifeCORE option) the frame or any part of the Product if it becomes defective, malfunctions, or otherwise fails to conform with this Limited Warranty. All labor for any required repair is warranted for 1 year from the date of original purchase. After one year all labor shall be the responsibility of the owner.

What is Not Covered. This Limited Warranty applies only for Product sold in the United States under the LifeCORE brand name. This warranty does not cover normal wear and tear on items such as, but not limited to, transportation wheels, foot pedals, rubber grips, plastic end caps, scratched parts, broken covers, cosmetic damage, and excludes paint & finish. Wear items pertain to components that might need to be replaced due to wear and tear resulting from normal usage. This warranty is void if the Product is improperly stored, installed, altered and/or modified in any way, misused, abused, is subject to accident, is improperly maintained, and this warranty does not cover repair for any noises such as: squeaks, clunks, thumps resulting from poor or lack of preventive maintenance. This Limited Warranty does extent to any Product that is damaged or rendered defective; (a) as a result of accident, misuse, or abuse; (b) use with the Product of any part not manufactured or sold by LifeCORE; (c) by modification of the Product; (d) by normal wear and tear; (e) operation using incorrect power supplies; or (f) as a result of service by anyone other than LifeCORE, or an authorized LifeCORE service provider. This Limited Warranty is void if the Product serial number has been defaced or removed. Should any Product be submitted for warranty service be found ineligible, an estimate of repair cost will be furnished.

Warranty Service Area. Any labor cost above the amount allocated by LifeCORE is the responsibility of the original purchaser. If a Product requires shipment, delivery or transport to an area that is not within a LifeCORE distribution area or is outside of a serviceable area is the purchaser's sole responsibility and to pay for any fees associated with servicing of a Product out of LifeCORE Fitness distribution or serviceable area. Any evidence of alteration, erasing or forgery of proof-of-purchase documents voids this Limited Warranty. This Limited Warranty applies only to Product purchased from LifeCORE or from an authorized LifeCORE reseller.

Disclaimed Warranties. TO THE MAXIMUM EXTENT ALLOWED BY LAW, ALL WARRANTIES, INCLUDING BUT NOT LIMITED TO EXPRESS WARRANTY, IMPLIED WARRANTY, WARRANTY OF MERCHANTABILITY, FITNESS FOR PARTICULAR PURPOSE AND WARRANTY OF NON-INFRINGEMENT OF INTELLECTUAL PROPERTY, ARE EXPRESSLY EXCLUDED TO THE MAXIMUM EXTENT PERMITTED BY LAW; AND LIFECORE NEITHER ASSUMES NOR AUTHORIZES ANY PERSON OR ENTITY TO ASSUME FOR IT ANY DUTY, OBLIGATION OR LIABILITY IN CONNECTION WITH ITS PRODUCTS. LIFECORE HEREBY DISCLAIMS AND HAS ABSOLUTELY NO LIABILITY FOR ANY AND ALL ACTS OF THIRD PARTIES INCLUDING DEALERS OR INSTALLERS. IN THE EVENT OF A CLAIM OR A DISPUTE INVOLVING LIFECORE OR ITS SUBSIDIARY, THE PROPER VENUE SHALL BE SAN DIEGO COUNTY IN THE STATE OF CALIFORNIA. CALIFORNIA STATE LAWS AND APPLICABLE FEDERAL LAWS SHALL APPLY AND GOVERN THE DISPUTE. THE MAXIMUM RECOVERY UNDER ANY CLAIM AGAINST LIFECORE SHALL BE STRICTLY LIMITED TO THE PURCHASE PRICE OF THE PART. LIFECORE SHALL NOT BE RESPONSIBLE FOR ANY DAMAGES WHATSOEVER, INCLUDING BUT NOT LIMITED TO, ANY CONSEQUENTIAL DAMAGES, INCIDENTAL DAMAGES, DAMAGES FOR THE LOSS OF TIME, LOSS OF EARNINGS, COMMERCIAL LOSS, LOSS OF ECONOMIC OPPORTUNITY AND THE LIKE.

Some states do not allow limitations on how long an implied warranty will last or the exclusion or limitation of incidental or consequential damages. This warranty gives you specific legal rights and you may also have other

rights that vary from State to State. LifeCORE does not and has not authorized any person or entity to create for it any other obligation, promise, duty or obligation in connection with this Product.

Warranty Registration. PLEASE SEND IN THE ATTACHED WARRANTY CARD WITHIN (10) DAYS OF PURCHASE TO REGISTER YOUR PRODUCT WITH LIFECORE FITNESS. PLEASE MAIL WARRANTY CARD TO: LIFECORE FITNESS, INC, 2575 Pioneer Ave. Suite 101. Vista, CA 92081. Phone (760)599-4555, Fax (760) 946-7602 or register online at LifeCOREfitness.com, Customer Service: 888-815-5559. Unless otherwise prohibited by law, in order to validate the warranty this Product must have been registered through LifeCORE Fitness Inc., and/or a copy of the proof of purchase, transferred warranty letter, and serial number must be presented at time of service. If these items are not presented at the time of requesting parts or service LifeCORE Fitness Inc. will not cover any warranty.

Warranty Claim Processing. To obtain warranty service, you must contact the original place of purchase. LifeCORE may at its option may repair or replace any defective Product frame or parts with new or serviceable used parts that are equivalent in function to the original parts. All exchanged frames and parts replaced under this warranty will at the time of service become the property of LifeCORE. LifeCORE reserves the right to change manufacturers of any parts to cover any existing warranty. Any parts determined to be defective must be returned to LifeCORE to obtain warranty service. You must prepay any shipping charges, export taxes, custom duties and taxes, or any other charges associated with transportation of the parts or Product. In addition, you are responsible for insuring any parts or Product shipped or returned. You assume the risk of loss during shipment.

Please see other LifeCORE Fitness Products at www.LifeCOREfitness.com.

THANK YOU FOR YOUR BUSINESS!

LC-CD400 Center Drive Elliptical

Please Attach a Copy of the Original Receipt

Full Name:

Address:

City: _____ State: _____ Zip Code: _____

Daytime Phone No.: _____ Cell Phone No.: _____

Email:

Dealer Purchased from: _____

Model: LC-CD400 Center Drive Elliptical Date Of Purchase: _____

Serial No. _____

Environment Placed: Residential Light Commercial Commercial



“We Fit Your Life”

Customer Service
Toll Free (888) 815-5559
Mon-Friday 7:30 - 5:30 PT
Service@lifecorefitness.com

Lifecore Fitness Inc.
2575 Pioneer Ave. Suite 101
Vista, CA 92081

Visit our website for assembly videos: www.lifecorefitness.com